

HOCHLEISTUNGSFRÄSER

BITTE BEACHTEN:

Die in diesem Katalog angegebenen Preise sind aus dem Jahr 2013 und nicht mehr aktuell.



Vielfalt vereint

| SOFTMILL ungleicher Drall | Z | Drall | Beschichtung coated | Art.-Nr. Art.-No. | STAHL steel | HSC | HRc 56 | INOX stainless steel | GUSS cast iron | Titan Inconell Hasteloy | ALU aluminium | NE non ferrous | Kunststoff plastic | Graphit graphite | Seite page |
|---|-----|----------------|---------------------|----------------------|----------------|-----|-----------|----------------------------|-------------------|-------------------------------|------------------|----------------------|-----------------------|---------------------|---------------|
| ungleiche Drallsteigung + ungleiche Schneidenteilung | | | | | | | | | | | | | | | |
| | 4 | 35° 38° | ZX4 | KF100 | ■ ■ | | | | ■ ■ | ■ ■ | | | | | 6 |
| | 3 | 41°/43° 45° | ZX4 | KF101 | ■ ■ | | | | ■ ■ | ■ ■ | | | | | 6 |
| | 4 | 36° 38° | ZX3 | KF102 | | | | ■ ■ | | | | | | | 7 |
| | 4 | 40° 42° | ohne | KF103 | | | | | | | ■ ■ | ■ | | | 7 |
| | 6 | 44°/45° 46° | ZX4 | KF110 | ■ ■ | | | ■ ■ | ■ ■ | ■ ■ | | | | | 8 |
| UNIVERSAL 30° (WERKNORM) | | | | | | | | | | | | | | | |
| VHM-Schaftfräser 30° - Kempf Norm - Ø 2,0 bis Ø 20,0 | | | | | | | | | | | | | | | |
| | 2 | 30° | ohne | KF342 | ■ | | | ■ | ■ | ■ | ■ | ■ | ■ | ■ | 9 |
| | 3 | 30° | ohne | KF343 | ■ | | | ■ | ■ | ■ | ■ | ■ | ■ | ■ | 9 |
| UNIVERSAL 30° LANG + EXTRA LANG | | | | | | | | | | | | | | | |
| VHM-Schaftfräser 30° - Baulänge DIN 6527 Lang und EXTRA LANG - Ø 2,0 bis Ø 20,0 | | | | | | | | | | | | | | | |
| | 2 | 30° | ZX4 | KF322 | ■ | | | ■ | ■ | ■ | ■ | ■ | ■ | ■ | 10 |
| | 3 | 30° | ZX4 | KF323 | ■ | | | ■ | ■ | ■ | ■ | ■ | ■ | ■ | 10 |
| | 4 | 30° | ZX4 | KF324 | ■ | | | ■ | ■ | ■ | ■ | ■ | ■ | ■ | 10 |
| | 2 | 30° | ZX4 | KF392 | ■ | | | ■ | ■ | ■ | ■ | ■ | ■ | ■ | 11 |
| | 3 | 30° | ZX4 | KF393 | ■ | | | ■ | ■ | ■ | ■ | ■ | ■ | ■ | 11 |
| | 4 | 30° | ZX4 | KF394 | ■ | | | ■ | ■ | ■ | ■ | ■ | ■ | ■ | 11 |
| UNIVERSAL 45° MINI + LANG | | | | | | | | | | | | | | | |
| VHM-Schaftfräser 45° - Werknorm (MINI) und Baulänge DIN 6527 Lang - Ø 0,5 bis Ø 20,0 | | | | | | | | | | | | | | | |
| | 3 | 45° | ZX3 | KF300 | ■ ■ | | | ■ | ■ ■ | ■ | ■ | ■ | | | 12 |
| SCHLICHTFRÄSER UNIVERSAL | | | | | | | | | | | | | | | |
| VHM-Schlichtfräser 45°/50° - Baulänge DIN 6527 Lang und EXTRA LANG - Ø 4,0 bis Ø 25,0 | | | | | | | | | | | | | | | |
| | 6-8 | 45° | ZX3 | KF308 | ■ ■ | | | ■ | ■ ■ | ■ | ■ | ■ | | | 13 |
| | 6-8 | 45° | ZX3 | KF309 | ■ ■ | | | ■ | ■ ■ | ■ | ■ | ■ | | | 13 |

Zeichenerklärung:



■ = Werkzeug gut geeignet









■ ■ = Werkzeug hervorragend geeignet (speziell für diesen Werkstoff entwickelt)

| RADIUSFRÄSER UNIVERSAL | | | | STAHL steel | HSC | HRc 70 | INOX stainless steel | GUSS cast iron | Titan Inconell Hasteloy | ALU aluminium | NE non ferrous | Kunststoff plastic | Graphit graphite | Seite page |
|--|-------|------|-------------|-------------|-----|--------|----------------------|----------------|-------------------------|---------------|----------------|--------------------|------------------|------------|
| VHM-Radiusfräser mit 2, 3 oder 4 Schneiden - kurze und extra lange Ausführung | | | | | | | | | | | | | | |
| | 2/3/4 | 30° | ohne o. ZX1 | KFB... | ■ | | ■ | ■ | ■ | ■ | ■ | ■ | ■ | 35 |
| | 2/3/4 | 30° | ohne o. ZX1 | KFB... | ■ | | ■ | ■ | ■ | ■ | ■ | ■ | ■ | 35 |
| ALU-FRÄSER KUNSTSTOFFE | | | | STAHL steel | HSC | HRc 70 | INOX stainless steel | GUSS cast iron | Titan Inconell Hasteloy | ALU aluminium | NE non ferrous | Kunststoff plastic | Graphit graphite | Seite page |
| VHM-Schaftfräser für Alu, Kunststoffe und NE-Metalle - Ø 3,0 bis Ø 20,0 | | | | | | | | | | | | | | |
| | 2 | 45° | ohne | KF302 | | | | | | ■ | ■ | ■ | | 14 |
| | 2 | 45° | ohne | KF396 | | | | | | ■ | ■ | | | 14 |
| | 3 | 45° | ohne | KF318 | | | | | | ■ | ■ | ■ | | 15 |
| VHM-HSC-Fräser mit geläppter Spannutt für Alu, Kunststoffe und NE-Metalle - Ø 2,0 bis Ø 20,0 | | | | | | | | | | | | | | |
| | 1 | 30° | ohne | KF535 | | | | | | ■ | | ■ | ■ | 16 |
| | 2 | 30° | ohne | KF536 | | | | | | ■ | | ■ | ■ | 17 |
| | 3 | 30° | ohne | KF537 | | | | | | ■ | | ■ | ■ | 17 |
| VHM-HSC-Fräser mit Diamantverzahnung für GFK, CFK und Kunststoffe - Ø 2,0 bis Ø 12,0 | | | | | | | | | | | | | | |
| | | | ohne | KF630 | | | | | | | | ■ | ■ | 18 |
| | | | ohne | KF631 | | | | | | | | ■ | ■ | 18 |
| | | | ohne | KF632 | | | | | | | | ■ | ■ | 19 |
| PKD-Schaftfräser ALU + NE-Metalle | | | | STAHL steel | HSC | HRc 70 | INOX stainless steel | GUSS cast iron | Titan Inconell Hasteloy | ALU aluminium | NE non ferrous | GFK CFK | Graphit graphite | Seite page |
| PKD-Schaftfräser für Aluminium und NE-Metalle | | | | | | | | | | | | | | |
| | 2 | 0° | ohne | KF910 | | | | | | ■ | ■ | ■ | ■ | 20 |
| | 2 | 2°+1 | ohne | KF915 | | | | | | ■ | ■ | ■ | ■ | 20 |
| | 2 | 2°+1 | ohne | KF920 | | | | | | ■ | ■ | ■ | ■ | 21 |
| | 2 | 0° | ohne | KFB910 | | | | | | ■ | ■ | ■ | ■ | 21 |
| GRAPHIT-FRÄSER KUNSTSTOFFE | | | | STAHL steel | HSC | HRc 70 | INOX stainless steel | GUSS cast iron | Titan Inconell Hasteloy | ALU aluminium | NE non ferrous | GFK CFK | Graphit graphite | Seite page |
| VHM-Schaftfräser mit Diamantbeschichtung für Graphit | | | | | | | | | | | | | | |
| | 2 | 30° | DIA | KF700 | | | | | | | ■ | ■ | ■ | 22 |
| | 2 | 30° | DIA | KFB700 | | | | | | | ■ | ■ | ■ | 23 |

Hinweis: Diamantbeschichtete VHM-Fräser ab Ø 0,3 bis Ø 3,0 finden Sie auf den Seiten 28 bis 33.

Zeichenerklärung:

















- = Werkzeug gut geeignet
- ■ = Werkzeug hervorragend geeignet (speziell für diesen Werkstoff entwickelt)

| MICRO-FRÄSER AB Ø 0,10 | Z | Drall | Beschichtung coated | Art.-Nr. Art.-No. | STAHL steel | HSC | HRC 56 | INOX stainless steel | GUSS cast iron | Titan Inconel Hasteloy | ALU aluminium | NE non ferrous | Kunststoff plastic | Graphit graphite | Seite page |
|--|-------|---------------------|----------------------|----------------------|----------------|-----------|----------------------------|----------------------------|------------------------------|------------------------------|----------------------|-----------------------|-----------------------|---------------------|---------------|
| VHM-Micro-Schaftfräser 30° - Ø 0,1 bis Ø 3,0 - Arbeitstiefe 1,5 x Ø und 2-3 x Ø | | | | | | | | | | | | | | | |
|  | 2 | 30° | ohne | KF350 - KF351 | ■ | | | | ■ ■ | | ■ ■ | ■ ■ | ■ ■ | | 28-29 |
|  | 2 | 30° | ZX3 | KF350 - KF351 | ■ ■ | | ■ | ■ ■ | ■ ■ | ■ ■ | ■ | ■ | | | 28-29 |
|  | 2 | 30° | DIA | KF350 - KF351 | | | | | | | ■ ■ | | ■ ■ | ■ ■ | 28-29 |
| VHM-Micro-Schaftfräser 30° - Ø 0,4 bis Ø 3,0 - Arbeitstiefe 5 x Ø und 8 x Ø | | | | | | | | | | | | | | | |
|  | 2 | 30° | ohne | KF352 - KF353 | ■ | | | | ■ ■ | | ■ ■ | ■ ■ | ■ ■ | | 30 |
|  | 2 | 30° | ZX3 | KF352 - KF353 | ■ ■ | | ■ | ■ ■ | ■ ■ | ■ ■ | ■ | ■ | | | 30 |
|  | 2 | 30° | DIA | KF352 - KF353 | | | | | | | ■ ■ | | ■ ■ | ■ ■ | 30 |
| VHM-Micro-Schaftfräser 30° - Ø 0,4 bis Ø 2,5 - Arbeitstiefe bis 15mm | | | | | | | | | | | | | | | |
|  | 2 | 30° | ohne | KF354 | ■ | | | | ■ ■ | | ■ ■ | ■ ■ | ■ ■ | | 31 |
|  | 2 | 30° | ZX3 | KF354 | ■ ■ | | ■ | ■ ■ | ■ ■ | ■ ■ | ■ | ■ | | | 31 |
|  | 2 | 30° | DIA | KF354 | | | | | | | ■ ■ | | ■ ■ | ■ ■ | 31 |
| VHM-Micro-Einzahnfräser - Ø 0,50 bis Ø 3,00 - Arbeitstiefe bis 3 x Ø | | | | | | | | | | | | | | | |
|  | 1 | 30° | ohne | KF535 | | | | | | | ■ ■ | | ■ ■ | | 16 |
| MICRO-FRÄSER RADIUSFRÄSER | | | | | | | | | | | | | | | |
| Z | Drall | Beschichtung coated | Art.-Nr. Art.-No. | STAHL steel | HSC | HRC 56 | INOX stainless steel | GUSS cast iron | Titan Inconel Hasteloy | ALU aluminium | NE non ferrous | Kunststoff plastic | Graphit graphite | Seite page | |
| VHM-Micro-Radiusfräser 30° - Ø 0,1 bis Ø 3,0 - Arbeitstiefe 1,5 x Ø und 2-3 x Ø | | | | | | | | | | | | | | | |
|  | 2 | 30° | ohne | KFB350 KFB351 | ■ | | | | ■ ■ | | ■ ■ | ■ ■ | ■ ■ | | 32 |
|  | 2 | 30° | ZX3 | KFB350 KFB351 | ■ ■ | | ■ | ■ ■ | ■ ■ | ■ ■ | ■ | ■ | | | 32 |
|  | 2 | 30° | DIA | KFB350 KFB351 | | | | | | | ■ ■ | | ■ ■ | ■ ■ | 32 |
| VHM-Micro-Radiusfräser 30° - Ø 0,4 bis Ø 2,5 - Arbeitstiefe bis 15mm | | | | | | | | | | | | | | | |
|  | 2 | 30° | ohne | KFB352 | ■ | | | | ■ ■ | | ■ ■ | ■ ■ | ■ ■ | | 33 |
|  | 2 | 30° | ZX3 | KFB352 | ■ ■ | | ■ | ■ ■ | ■ ■ | ■ ■ | ■ | ■ | | | 33 |
|  | 2 | 30° | DIA | KFB352 | | | | | | | ■ ■ | | ■ ■ | ■ ■ | 33 |
| VHM-Micro-Kugelfräser 30° - Ø 0,8 bis Ø 5,0 | | | | | | | | | | | | | | | |
|  | 2 | 30° | ZX3 | KFB510 | ■ ■ | | ■ | ■ ■ | | ■ ■ | | | | | 39 |
| VHM-Micro-1/4-Kreis Konkavfräser | | | | | | | | | | | | | | | |
|  | 2 | 0° | ohne | KF616 | ■ | | ■ | ■ | | | ■ | ■ | ■ | | 34 |
| UNIVERSAL-TOOL 60° - 90° - 120° | | | | | | | | | | | | | | | |
| Z | Drall | Beschichtung coated | Art.-Nr. Art.-No. | STAHL steel | HSC | HRC 70 | INOX stainless steel | GUSS cast iron | Titan Inconel Hasteloy | ALU aluminium | NE non ferrous | Kunststoff plastic | Graphit graphite | Seite page | |
| VHM-Werkzeug zum Fräsen, Bohren und Senken mit nur einem Werkzeug | | | | | | | | | | | | | | | |
|  | 90° | 2 | 30° | ohne o. ZX3 | KF620 | ■ | | ■ | ■ | ■ | ■ | ■ | ■ | | 26 |
|  | 60° | 2 | 30° | ohne o. ZX3 | KF621 | ■ | | ■ | ■ | ■ | ■ | ■ | ■ | | 27 |
|  | 120° | 2 | 30° | ohne o. ZX3 | KF622 | ■ | | ■ | ■ | ■ | ■ | ■ | ■ | | 27 |

Zeichenerklärung:

- = Werkzeug gut geeignet
- ■ = Werkzeug hervorragend geeignet (speziell für diesen Werkstoff entwickelt)

Inhaltsverzeichnis

| KOPIERFRÄSER HARTFRÄSER | Z | Drall | Beschichtung coated | Art.-Nr. Art.-No. | STAHL | HSC | HRC | INOX | GUSS | Titan | ALU | NE | Kunststoff | Graphit | Seite page |
|--|-----|-------|---------------------|----------------------|-------|-----|-----|-----------------|-----------|---------------------|-----------|-------------|------------|----------|---------------|
| | | | | | steel | | <65 | stainless steel | cast iron | Inconel Hasteloy | aluminium | non ferrous | plastic | graphite | |
| VHM-HSC-Kopierfräser | | | | | | | | | | | | | | | |
|  | 2 | 30° | ZX3 | KFB502 | ■ | ■ | ■ | | ■ | | | | | | 36 |
|  | 2 | 30° | ZX3 | KFB503 | ■ | ■ | ■ | | ■ | | | | | | 36 |
|  | 2 | 15° | ZX3 | KFB516 | ■ | ■ | ■ | | | | | | | | 37 |
|  | 2 | 30° | ZX3 | KFB506 | ■ | ■ | ■ | | ■ | | | | | | 38 |
|  | 2 | 30° | ZX3 | KFB512 | ■ | ■ | ■ | | ■ | | | | | | 40 |
|  | 4 | 30° | ZX3 | KFB514 | ■ | ■ | ■ | | ■ | | | | | | 40 |
|  | 4 | 30° | ZX3 | KFB504 | ■ | ■ | ■ | | ■ | | | | | | 39 |
| VHM-HSC-Schaftfräser | | | | | | | | | | | | | | | |
|  | 2 | 30° | ZX3 | KF502 | ■ | | ■ | | ■ | | | | | | 44 |
|  | 4 | 30° | ZX3 | KF504 | ■ | ■ | ■ | | ■ | | | | | | 45 |
|  | 6-8 | 45° | ZX3 | KF600 KF602 | ■ | ■ | ■ | | | | | | | | 41 |
| VHM-HSC-Schaftfräser mit Eckenradius | | | | | | | | | | | | | | | |
|  | 2 | 30° | ZX3 | KF506 | ■ | | ■ | | ■ | | | | | | 42 |
|  | 4 | 30° | ZX3 | KF508 KF509 | ■ | | ■ | | ■ | | | | | | 43 |
| SCHRUPPFÄSER Stahl/Alu/Universell | | | | | | | | | | | | | | | |
| SCHRUPPFÄSER Stahl/Alu/Universell | Z | Drall | Beschichtung coated | Art.-Nr. Art.-No. | STAHL | HSC | HRC | INOX | GUSS | Titan | ALU | NE | Kunststoff | Graphit | Seite page |
| | | | | | steel | | <65 | stainless steel | cast iron | Inconel Hasteloy | aluminium | non ferrous | plastic | graphite | |
| VHM-Schrupp-Schlichtfräser | | | | | | | | | | | | | | | |
|  | 3-4 | 30° | ZX5 | KF306 | ■ | | | ■ | ■ | ■ | ■ | ■ | ■ | ■ | 25 |
| VHM-Schrupfräser und VHM-Schrupfräser mit Innenkühlung | | | | | | | | | | | | | | | |
|  | 3-5 | 20° | ZX3 | KF310 KF311 | ■ | | ■ | | ■ | | | | | | 24 |
|  | 3-4 | 20° | ZX3 | KFB311 | ■ | | ■ | | ■ | | | | | | 24 |
|  | 4 | 30° | ZX4 | KF319 | ■ | | | ■ | ■ | ■ | | | | | 25 |
| VHM-ALU-Schrupfräser und VHM-ALU-Schrupfräser mit Innenkühlung | | | | | | | | | | | | | | | |
|  | 3 | 30° | ohne | KF312 | | | | | | | ■ | ■ | ■ | | 15 |
|  | 3 | 30° | ohne | KF313 | | | | | | | ■ | ■ | ■ | | 15 |
| KEMPF BESCHICHTUNGSVARIANTEN SEITE 34 / Kempf coating types page 34 | | | | | | | | | | | | | | | |
| ANFRAGEBOGEN FÜR VHM-SONDERFRÄSER SEITE 46 / questionnaire for special solid carbide end mills page 46 | | | | | | | | | | | | | | | |

Zeichenerklärung:

- = Werkzeug gut geeignet
- ■ = Werkzeug hervorragend geeignet (speziell für diesen Werkstoff entwickelt)

SOFTMILL TYP UNI

4-Schneidig

KF100 - ZX4



Einsatzgebiete: Universell einsetzbar, mit 35°/38° Spirale optimal zum Nuten, Schruppen und Schlichten in Stahl, hochlegiertem Stahl und gehärtetem Stahl bis 1600N/mm².

application: Universal use, due to 35°/38° helix particularly suitable for grooving, roughing and finishing of steel, high-alloy steel and hardened steel up to 1600N/mm²



| STAHL steel | GUSS cast iron | TITAN-Sonderleg. | * Kantenschutz *** | | | | | |
|-------------|----------------|------------------|--------------------|-------------|-------------|-------------|-------------|-------------|
| | | | Ø 4 - Ø 5 | Ø 6 - Ø 8 | Ø 10 - Ø 12 | Ø 16 | Ø 20 | Ø 25 |
| | | | 0,1 x 45° | 0,150 x 45° | 0,200 x 45° | 0,350 x 45° | 0,450 x 45° | 0,600 x 45° |

- ab Lager / ex stock
- kurzfristig / on short notice
- Lieferzeit auf Anfrage / delivery time upon request

| d1 h10 mm | d2 h6 mm | d3 mm | l1 mm | l2 mm | l3 mm | Artikel-Nr. (code no.) Schaft HB | Preis Euro / je Schaft HB | Artikel-Nr. (code no.) Schaft HA | Preis Euro / je Schaft HA |
|-----------------|----------------|----------|----------|----------|----------|--|---------------------------------|--|---------------------------------|
| 4,00 | 6,0 | 3,7 | 57,0 | 11,0 | 18,0 | KF100040ZX4B | 17,20 | KF100040ZX4 | 15,80 |
| 5,00 | 6,0 | 4,7 | 57,0 | 13,0 | 18,0 | KF100050ZX4B | 17,20 | KF100050ZX4 | 15,80 |
| 6,00 | 6,0 | 5,5 | 57,0 | 13,0 | 21,0 | KF100060ZX4B | 20,80 | KF100060ZX4 | 19,60 |
| 8,00 | 8,0 | 7,5 | 63,0 | 19,0 | 27,0 | KF100080ZX4B | 28,80 | KF100080ZX4 | 27,60 |
| 10,00 | 10,0 | 9,2 | 72,0 | 22,0 | 32,0 | KF100100ZX4B | 42,40 | KF100100ZX4 | 40,80 |
| 12,00 | 12,0 | 11,2 | 83,0 | 26,0 | 38,0 | KF100120ZX4B | 54,40 | KF100120ZX4 | 52,80 |
| 16,00 | 16,0 | 15,0 | 92,0 | 32,0 | 44,0 | KF100160ZX4B | 95,20 | KF100160ZX4 | 91,20 |
| 20,00 | 20,0 | 19,0 | 104,0 | 38,0 | 54,0 | KF100200ZX4B | 144,80 | KF100200ZX4 | 141,60 |
| 25,00 | 25,0 | 23,5 | 121,0 | 45,0 | 65,0 | KF100250ZX4B | 230,40 | KF100250ZX4 | 224,00 |

SOFTMILL TYP UNI

3-Schneidig

KF101 - ZX4



Einsatzgebiete: Mit 41°/43°/45° Spirale universell einsetzbar zum Nuten, Schruppen und Schlichten in Stahl, hochlegiertem Stahl und gehärtetem Stahl bis 1400N/mm² (44 HRC). Als 3-Schneider mit größerem Spanraum auch für extrem hohe Schnitttiefen einsetzbar.

application: Due to 41°/43°/45° helix universal use, well suited for grooving, roughing and finishing operations in steel, high-alloy steel and hardened steel up to 1400N/mm² (44HRC). This end mill with 3 flutes and additional chip space can be used for operations with extrem cutting depths.



| STAHL steel | GUSS cast iron | TITAN-Sonderleg. | * Kantenschutz *** | | |
|-------------|----------------|------------------|--------------------|-------------|-------------|
| | | | Ø 3 - Ø 6 | Ø 8 - Ø 10 | Ø 12 - Ø 20 |
| | | | 0,05 x 45° | 0,100 x 45° | 0,150 x 45° |

- ab Lager / ex stock
- kurzfristig / on short notice
- Lieferzeit auf Anfrage / delivery time upon request

| d1 h10 mm | d2 h6 mm | d3 mm | l1 mm | l2 mm | l3 mm | Artikel-Nr. (code no.) Schaft HB | Preis Euro / je Schaft HB | Artikel-Nr. (code no.) Schaft HA | Preis Euro / je Schaft HA |
|-----------------|----------------|----------|----------|----------|----------|--|---------------------------------|--|---------------------------------|
| 3,00 | 6,0 | 2,7 | 57,0 | 8,0 | 15,0 | KF101030ZX4B | 20,00 | KF101030ZX4 | 18,60 |
| 4,00 | 6,0 | 3,7 | 57,0 | 11,0 | 18,0 | KF101040ZX4B | 20,00 | KF101040ZX4 | 18,60 |
| 5,00 | 6,0 | 4,7 | 57,0 | 13,0 | 18,0 | KF101050ZX4B | 20,00 | KF101050ZX4 | 18,60 |
| 6,00 | 6,0 | 5,5 | 57,0 | 13,0 | 21,0 | KF101060ZX4B | 24,80 | KF101060ZX4 | 23,40 |
| 8,00 | 8,0 | 7,5 | 63,0 | 19,0 | 27,0 | KF101080ZX4B | 33,60 | KF101080ZX4 | 32,20 |
| 10,00 | 10,0 | 9,2 | 72,0 | 22,0 | 32,0 | KF101100ZX4B | 50,00 | KF101100ZX4 | 48,00 |
| 12,00 | 12,0 | 11,2 | 83,0 | 26,0 | 38,0 | KF101120ZX4B | 64,40 | KF101120ZX4 | 62,40 |
| 16,00 | 16,0 | 15,0 | 92,0 | 32,0 | 44,0 | KF101160ZX4B | 110,40 | KF101160ZX4 | 107,00 |
| 20,00 | 20,0 | 19,0 | 104,0 | 38,0 | 54,0 | KF101200ZX4B | 167,80 | KF101200ZX4 | 164,40 |

SOFTMILL TYP INOX

4-Schneidig

KF102 - ZX3

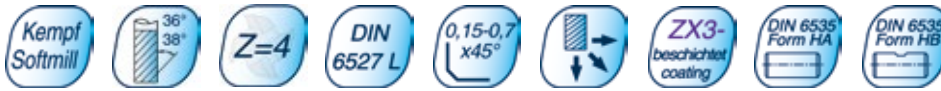

Einsatzgebiete: Hochleistungsfräser besonders gut geeignet zur Bearbeitung von VA-Stählen bzw. rostfreien Stählen mit verbesserter Spanabfuhr. Einsetzbar zum Schlichten, Schrupp-Schlichten und Schruppen mit einem Werkzeug.

application: High-performance end mill with improved chip removal well suited to machine VA-steels and stainless steels, for fine finishing, finishing, rough finishing and roughing operations with but one single tool.



| * Kantenschutz *** | | | | | | |
|--------------------|------------|------------|------------|------------|------------|------------|
| Ø 6 | Ø 8 | Ø 10 | Ø 12 | Ø 16 | Ø 20 | Ø 25 |
| 0,2 x 45° | 0,25 x 45° | 0,30 x 45° | 0,35 x 45° | 0,50 x 45° | 0,60 x 45° | 0,75 x 45° |

- ab Lager / ex stock
- kurzfristig / on short notice
- Lieferzeit auf Anfrage / delivery time upon request

| d1 | d2 | d3 | l1 | l2 | l3 | Artikel-Nr. (code no.) Schaft HB | Preis Euro / je Schaft HB | Artikel-Nr. (code no.) Schaft HA | Preis Euro / je Schaft HA |
|-------|------|------|-------|------|------|--|---------------------------------|--|---------------------------------|
| 4,00 | 6,0 | 3,7 | 54,0 | 8,0 | 15,0 | KF102040ZX3B | 23,40 | KF102040ZX3 | 22,00 |
| 5,00 | 6,0 | 4,7 | 54,0 | 9,0 | 15,0 | KF102050ZX3B | 23,40 | KF102050ZX3 | 22,00 |
| 6,00 | 6,0 | 5,5 | 57,0 | 13,0 | 21,0 | KF102060ZX3B | 27,40 | KF102060ZX3 | 25,80 |
| 8,00 | 8,0 | 7,5 | 63,0 | 19,0 | 27,0 | KF102080ZX3B | 37,00 | KF102080ZX3 | 35,80 |
| 10,00 | 10,0 | 9,2 | 72,0 | 22,0 | 32,0 | KF102100ZX3B | 55,60 | KF102100ZX3 | 53,60 |
| 12,00 | 12,0 | 11,2 | 83,0 | 26,0 | 38,0 | KF102120ZX3B | 71,40 | KF102120ZX3 | 68,60 |
| 16,00 | 16,0 | 15,0 | 92,0 | 32,0 | 44,0 | KF102160ZX3B | 122,60 | KF102160ZX3 | 118,60 |
| 20,00 | 20,0 | 19,0 | 104,0 | 38,0 | 54,0 | KF102200ZX3B | 186,40 | KF102200ZX3 | 183,60 |
| 25,00 | 25,0 | 23,5 | 121,0 | 45,0 | 65,0 | KF102250ZX3B | 297,20 | KF102250ZX3 | 291,80 |

SOFTMILL TYP ALU

4-Schneidig

KF103

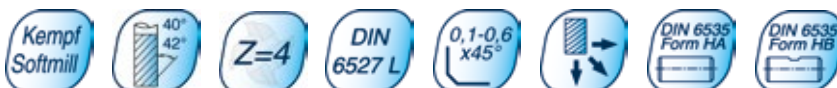

Einsatzgebiete: VHM-Hochleistungsfräser besonders gut geeignet zum Fräsen von Aluminium-Werkstoffen. Mit 40°/42° Spiralwinkel auch optimal für länger spanende Werkstoffe sowie NE-Metalle geeignet.

application: Solid carbide high-performance end mill particularly well suited to machine aluminium materials. Due to the 40°/42° helix also well suited to machine long-chipping materials such as nonferrous metals.

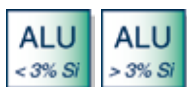
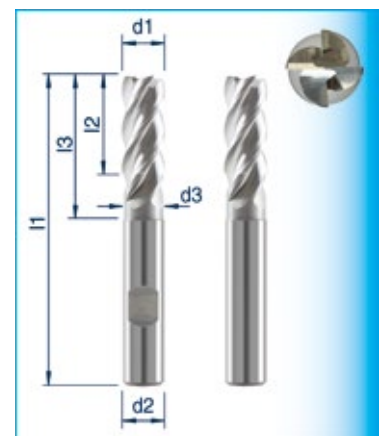

| * Kantenschutz *** | | | | |
|--------------------|-------------|-------------|-------------|-------------|
| Ø 4 - Ø 5 | Ø 6 - Ø 8 | Ø 10 - Ø 12 | Ø 16 | Ø 20 |
| 0,1 x 45° | 0,150 x 45° | 0,200 x 45° | 0,350 x 45° | 0,450 x 45° |

- ab Lager / ex stock
- kurzfristig / on short notice
- Lieferzeit auf Anfrage / delivery time upon request

| d1 | d2 | d3 | l1 | l2 | l3 | Artikel-Nr. (code no.) Schaft HB | Preis Euro / je Schaft HB | Artikel-Nr. (code no.) Schaft HA | Preis Euro / je Schaft HA |
|-------|------|------|-------|------|------|--|---------------------------------|--|---------------------------------|
| 4,00 | 6,0 | 3,7 | 57,0 | 11,0 | 18,0 | KF103040ALUB | 18,00 | KF103040ALU | 16,60 |
| 5,00 | 6,0 | 4,7 | 57,0 | 13,0 | 18,0 | KF103050ALUB | 18,00 | KF103050ALU | 16,60 |
| 6,00 | 6,0 | 5,5 | 57,0 | 13,0 | 21,0 | KF103060ALUB | 18,00 | KF103060ALU | 16,60 |
| 8,00 | 8,0 | 7,5 | 63,0 | 19,0 | 27,0 | KF103080ALUB | 20,60 | KF103080ALU | 19,00 |
| 10,00 | 10,0 | 9,2 | 72,0 | 22,0 | 32,0 | KF103100ALUB | 34,00 | KF103100ALU | 32,00 |
| 12,00 | 12,0 | 11,2 | 83,0 | 26,0 | 38,0 | KF103120ALUB | 47,40 | KF103120ALU | 44,60 |
| 16,00 | 16,0 | 15,0 | 92,0 | 32,0 | 44,0 | KF103160ALUB | 78,80 | KF103160ALU | 74,80 |
| 20,00 | 20,0 | 19,0 | 104,0 | 38,0 | 54,0 | KF103200ALUB | 129,60 | KF103200ALU | 125,40 |

SOFTMILL TYP UNI-SCHLICHT

6-Schneidig

KF110 - ZX4



Einsatzgebiete: Dieser Schlichtfräser eignet sich bestens für Feinstschlicht-HSC-Operationen und zum Semischruppen mit Zustellbreiten von $0,3 \times D$. Durch hohe Drallwinkel werden extrem gute Oberflächenqualitäten erzielt.

application: This roughing end mill is optimally suited for fine finishing operations and for semi-roughing operations with feed widths of up to $0.3 \times \varnothing$. Due to large helix angles super surface finishes can be obtained.



| * Kantenschutz *** | | |
|----------------------------------|-----------------------------------|-------------------------|
| $\varnothing 8 - \varnothing 10$ | $\varnothing 12 - \varnothing 20$ | $\varnothing 25$ |
| $0,100 \times 45^\circ$ | $0,150 \times 45^\circ$ | $0,200 \times 45^\circ$ |



- ab Lager / ex stock
- kurzfristig / on short notice
- Lieferzeit auf Anfrage / delivery time upon request

| d1 | d2 | d3 | l1 | l2 | l3 | Artikel-Nr. (code no.) | Preis Euro / je Schaft HB | Artikel-Nr. (code no.) Schaft HA | Preis Euro / je Schaft HA |
|-------|------|------|-------|------|------|---------------------------|---------------------------------|--|---------------------------------|
| 8,00 | 8,0 | 7,5 | 63,0 | 19,0 | 27,0 | KF110080ZX4B | • 30,60 | KF110080ZX4 | • 28,80 |
| 10,00 | 10,0 | 9,5 | 72,0 | 22,0 | 32,0 | KF110100ZX4B | • 48,80 | KF110100ZX4 | • 46,60 |
| 12,00 | 12,0 | 11,2 | 83,0 | 26,0 | 38,0 | KF110120ZX4B | • 65,20 | KF110120ZX4 | • 62,40 |
| 16,00 | 16,0 | 15,0 | 92,0 | 32,0 | 44,0 | KF110160ZX4B | • 117,20 | KF110160ZX4 | • 111,80 |
| 20,00 | 20,0 | 19,0 | 104,0 | 38,0 | 54,0 | KF110200ZX4B | • 167,20 | KF110200ZX4 | • 160,40 |
| 25,00 | 25,0 | 23,5 | 121,0 | 45,0 | 65,0 | KF110250ZX4B | • 297,20 | KF110250ZX4 | • 291,80 |

VHM-SCHAFTFRÄSER 30°

KF342 und KF343



Einsatzgebiete: Universell einsetzbar, sowohl für hochfeste Werkstoffe als auch für Alu und NE-Metalle geeignet.

application: Universal applications. Suitable for high hard materials as well as aluminium and nonferrous metals.

KF342 = 2 Schneiden mit Zentrumschnitt / 2 cutting edges, center cutting

KF343 = 3 Schneiden mit Zentrumschnitt / 3 cutting edges, center cutting

| * Durchmessertoleranz (Ø-tolerance) „e8“: | | | | |
|---|-----------------|-----------------|-----------------|-----------------|
| Ø 2 - Ø 3 | Ø 3 - Ø 6 | Ø 6 - Ø 10 | Ø 10 - Ø 18 | Ø 18 - Ø 20 |
| -0,014 / -0,028 | -0,020 / -0,038 | -0,025 / -0,047 | -0,032 / -0,059 | -0,040 / -0,073 |



KF342 = Z2

KF343 = Z3

universell einsetzbar

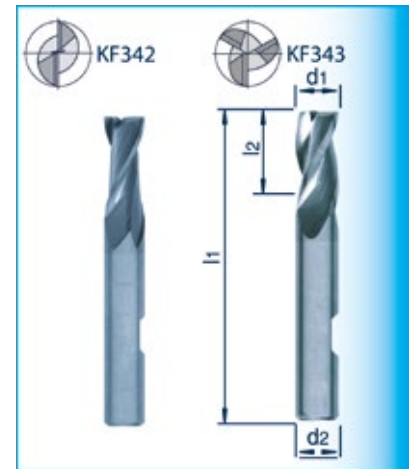

- ab Lager / ex stock
- kurzfristig / on short notice
- Lieferzeit auf Anfrage / delivery time upon request

| d1 e8* mm | d2 h6 mm | l2 mm | l1 mm | Artikel-Nr. (code no.) | Preis Euro / je KF342 | Artikel-Nr. (code no.) | Preis Euro / je KF343 |
|-----------------|----------------|----------|----------|---------------------------|-----------------------------|---------------------------|-----------------------------|
| • 2,0 | 2,0 | 8 | 32 | KF342020 | 7,60 | KF343020 | 7,60 |
| • 2,5 | 2,5 | 8 | 32 | KF342025 | 7,60 | KF343025 | 7,60 |
| • 3,0 | 3,0 | 12 | 32 | KF342030 | 7,60 | KF343030 | 7,60 |
| • 3,5 | 3,5 | 12 | 32 | KF342035 | 7,60 | KF343035 | 7,60 |
| • 4,0 | 4,0 | 12 | 40 | KF342040 | 8,00 | KF343040 | 8,00 |
| • 4,5 | 4,5 | 14 | 50 | KF342045 | 9,80 | KF343045 | 9,80 |
| • 5,0 | 5,0 | 14 | 50 | KF342050 | 9,80 | KF343050 | 9,80 |
| • 5,5 | 5,5 | 16 | 50 | KF342055 | 11,00 | KF343055 | 11,00 |
| • 6,0** | 6,0 | 14 | 50 | KF342060 | 11,00 | KF343060 | 11,00 |
| • 6,5 | 6,5 | 16 | 50 | KF342065 | 14,80 | KF343065 | 14,80 |
| • 7,0 | 7,0 | 20 | 60 | KF342070 | 14,80 | KF343070 | 14,80 |
| • 7,5 | 7,5 | 20 | 60 | KF342075 | 15,00 | KF343075 | 15,00 |
| • 8,0** | 8,0 | 18 | 60 | KF342080 | 15,00 | KF343080 | 15,00 |
| • 8,5 | 8,5 | 20 | 60 | KF342085 | 19,60 | KF343085 | 19,60 |
| • 9,0 | 9,0 | 20 | 60 | KF342090 | 19,60 | KF343090 | 19,60 |
| • 9,5 | 9,5 | 22 | 70 | KF342095 | 23,00 | KF343095 | 23,00 |
| • 10,0** | 10,0 | 20 | 70 | KF342100 | 23,00 | KF343100 | 23,00 |
| • 11,0 | 11,0 | 22 | 70 | KF342110 | 30,80 | KF343110 | 30,80 |
| • 12,0** | 12,0 | 20 | 70 | KF342120 | 30,80 | KF343120 | 30,80 |
| • 13,0 | 13,0 | 25 | 75 | KF342130 | 44,00 | KF343130 | 44,00 |
| • 14,0** | 14,0 | 22 | 75 | KF342140 | 41,60 | KF343140 | 41,60 |
| • 15,0 | 15,0 | 25 | 75 | KF342150 | 58,00 | KF343150 | 58,00 |
| • 16,0** | 16,0 | 22 | 75 | KF342160 | 54,60 | KF343160 | 54,60 |
| • 18,0** | 18,0 | 32 | 100 | KF342180 | 76,40 | KF343180 | 76,40 |
| • 20,0** | 20,0 | 30 | 100 | KF342200 | 81,00 | KF343200 | 81,00 |

** mit Weldon-Spannfläche DIN 6535 Form HB (with weldon flat)

VHM-SCHAFTFRÄSER 30°

KF322 / KF323 / KF324 - ZX4



Einsatzgebiete: Universell einsetzbar, sowohl für hochfeste Werkstoffe als auch für Alu und NE-Metalle geeignet.

application: Universal applications. Suitable for high hard materials as well as aluminium and nonferrous metals.

KF322 = 2 Schneiden mit Zentrumschnitt / 2 cutting edges, center cutting

KF323 = 3 Schneiden mit Zentrumschnitt / 3 cutting edges, center cutting

KF324 = 4 Schneiden mit Zentrumschnitt / 4 cutting edges, center cutting

Schutzfase / protection chamfer:

| $\varnothing 2 - \varnothing 6$ | $\varnothing 8 - \varnothing 10$ | $\varnothing 12$ | $\varnothing 14 - \varnothing 20$ |
|---------------------------------|----------------------------------|------------------|-----------------------------------|
| 0,05 -0,02 | 0,10 -0,02 | 0,15 -0,02 | 0,15 \pm 0,02 |

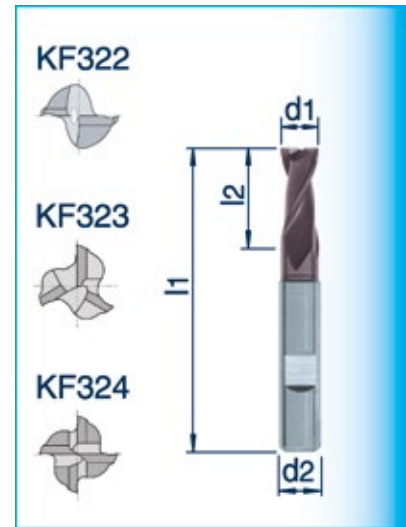

- ab Lager / ex stock
- kurzfristig / on short notice
- Lieferzeit auf Anfrage / delivery time upon request

VHM-Schaftfräser KF322 = 2-Schneiden / KF323 = 3-Schneiden

| d1 h10 mm | d2 h6 mm | l2 mm | l1 mm | Zähnezahl (no. of cutting edges) | Artikel-Nr. (code no.) | Preis Euro / je KF322 - ZX4 | Zähnezahl (no. Of cutting edges) | Artikel-Nr. (code no.) | Preis Euro / je KF323 - ZX4 |
|-----------------|----------------|----------|----------|--|---------------------------|-----------------------------------|--|---------------------------|-----------------------------------|
| • 2,0 | 6 | 6 | 57 | 2 | KF322020ZX4 | 13,60 | 3 | KF323020ZX4 | 13,60 |
| • 3,0 | 6 | 7 | 57 | 2 | KF322030ZX4 | 13,60 | 3 | KF323030ZX4 | 13,60 |
| • 4,0 | 6 | 8 | 57 | 2 | KF322040ZX4 | 12,80 | 3 | KF323040ZX4 | 12,80 |
| • 5,0 | 6 | 10 | 57 | 2 | KF322050ZX4 | 12,80 | 3 | KF323050ZX4 | 12,80 |
| • 6,0 | 6 | 10 | 57 | 2 | KF322060ZX4 | 12,00 | 3 | KF323060ZX4 | 12,00 |
| • 7,0 | 8 | 13 | 63 | 2 | KF322070ZX4 | 19,80 | 3 | KF323070ZX4 | 19,80 |
| • 8,0 | 8 | 16 | 63 | 2 | KF322080ZX4 | 16,40 | 3 | KF323080ZX4 | 16,40 |
| • 9,0 | 10 | 16 | 72 | 2 | KF322090ZX4 | 28,40 | 3 | KF323090ZX4 | 28,40 |
| • 10,0 | 10 | 19 | 72 | 2 | KF322100ZX4 | 24,00 | 3 | KF323100ZX4 | 24,00 |
| • 12,0 | 12 | 22 | 83 | 2 | KF322120ZX4 | 34,00 | 3 | KF323120ZX4 | 34,00 |
| • 14,0 | 14 | 22 | 83 | 2 | KF322140ZX4 | 46,60 | 3 | KF323140ZX4 | 46,60 |
| • 16,0 | 16 | 26 | 92 | 2 | KF322160ZX4 | 56,40 | 3 | KF323160ZX4 | 56,40 |
| • 18,0 | 18 | 26 | 92 | 2 | KF322180ZX4 | 80,80 | 3 | KF323180ZX4 | 80,80 |
| • 20,0 | 20 | 32 | 104 | 2 | KF322200ZX4 | 84,60 | 3 | KF323200ZX4 | 84,60 |

VHM-Schaftfräser KF324 = 4-Schneiden

| d1 h10 mm | d2 h6 mm | l2 mm | l1 mm | Zähnezahl (no. of cutting edges) | Artikel-Nr. (code no.) | Preis Euro / je KF324 - ZX4 |
|-----------------|----------------|----------|----------|--|---------------------------|-----------------------------------|
| • 2,0 | 6 | 7 | 57 | 4 | KF324020ZX4 | 13,40 |
| • 3,0 | 6 | 8 | 57 | 4 | KF324030ZX4 | 14,20 |
| • 4,0 | 6 | 11 | 57 | 4 | KF324040ZX4 | 14,20 |
| • 5,0 | 6 | 13 | 57 | 4 | KF324050ZX4 | 14,80 |
| • 6,0 | 6 | 13 | 57 | 4 | KF324060ZX4 | 14,80 |
| • 7,0 | 8 | 16 | 63 | 4 | KF324070ZX4 | 17,40 |
| • 8,0 | 8 | 19 | 63 | 4 | KF324080ZX4 | 17,40 |
| • 9,0 | 10 | 19 | 72 | 4 | KF324090ZX4 | 22,40 |
| • 10,0 | 10 | 22 | 72 | 4 | KF324100ZX4 | 27,40 |
| • 12,0 | 12 | 26 | 83 | 4 | KF324120ZX4 | 37,20 |
| • 14,0 | 14 | 26 | 83 | 4 | KF324140ZX4 | 47,20 |
| • 16,0 | 16 | 32 | 92 | 4 | KF324160ZX4 | 62,60 |
| • 18,0 | 18 | 32 | 92 | 4 | KF324180ZX4 | 80,00 |
| • 20,0 | 20 | 38 | 104 | 4 | KF324200ZX4 | 99,00 |

VHM-SCHAFTFRÄSER 30° EXTRA LANG KF392 / KF393 / KF394 - ZX4



Einsatzgebiete: Universell einsetzbar, sowohl für hochfeste Werkstoffe als auch für Alu und NE-Metalle geeignet.

application: Universal applications. Suitable for high hard materials as well as aluminium and nonferrous metals.

KF392 EXTRA LANG = 2 Schneiden mit Zentrumschnitt / 2 cutting edges, center cutting, EXTRA LONG

KF393 EXTRA LANG = 3 Schneiden mit Zentrumschnitt / 3 cutting edges, center cutting, EXTRA LONG

KF394 EXTRA LANG = 4 Schneiden mit Zentrumschnitt / 4 cutting edges, center cutting, EXTRA LONG

| Schutzfase / protection chamfer: | | | |
|----------------------------------|-------------|-------------|-------------|
| Ø 2 - Ø 6 | Ø 8 - Ø 10 | Ø 12 | Ø 14 - Ø 20 |
| 0,05 - 0,02 | 0,10 - 0,02 | 0,15 - 0,02 | 0,15 ± 0,02 |

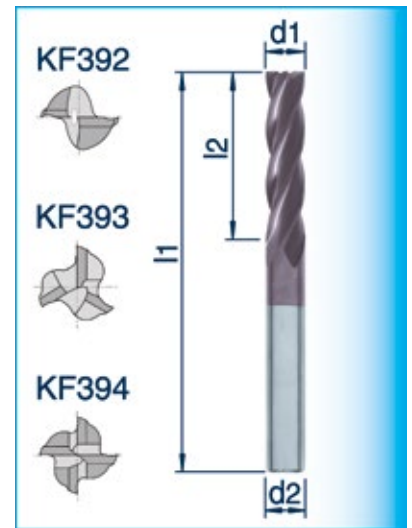

- ab Lager / ex stock
- kurzfristig / on short notice
- Lieferzeit auf Anfrage / delivery time upon request

VHM-Schaftfräser KF392 Extra Lang - 2-Schneiden - ZX4

| d1 | d2 | l2 | l1 | Zähnezahl | Artikel-Nr. (code no.) | Preis | Artikel-Nr. (code no.) | Preis |
|--------|----|----|-----|----------------|------------------------|-------------|------------------------|-------------|
| h10 | h6 | | | (no. of | ohne Spannfläche | Euro / je | mit Spannfläche | Euro / je |
| mm | mm | mm | mm | cutting edges) | without Weldon flat | KF392 - ZX4 | with Weldon flat | KF392 - ZX4 |
| • 3,0 | 3 | 20 | 75 | 2 | KF392030ZX4 | 14,20 | --- | --- |
| • 4,0 | 4 | 25 | 75 | 2 | KF392040ZX4 | 16,20 | --- | --- |
| • 5,0 | 5 | 30 | 75 | 2 | KF392050ZX4 | 17,40 | --- | --- |
| • 6,0 | 6 | 30 | 75 | 2 | KF392060ZX4 | 21,80 | KF392060WZX4 | 24,00 |
| • 8,0 | 8 | 40 | 100 | 2 | KF392080ZX4 | 27,40 | KF392080WZX4 | 29,80 |
| • 10,0 | 10 | 40 | 100 | 2 | KF392100ZX4 | 33,20 | KF392100WZX4 | 35,60 |
| • 12,0 | 12 | 45 | 150 | 2 | KF392120ZX4 | 51,20 | KF392120WZX4 | 55,80 |
| • 14,0 | 14 | 45 | 150 | 2 | KF392140ZX4 | 62,60 | KF392140WZX4 | 67,20 |
| • 16,0 | 16 | 65 | 150 | 2 | KF392160ZX4 | 83,20 | KF392160WZX4 | 87,80 |
| • 18,0 | 18 | 65 | 150 | 2 | KF392180ZX4 | 99,00 | KF392180WZX4 | 103,60 |
| • 20,0 | 20 | 65 | 150 | 2 | KF392200ZX4 | 112,80 | KF392200WZX4 | 117,40 |

VHM-Schaftfräser KF393 Extra Lang - 3-Schneiden - ZX4

| d1 | d2 | l2 | l1 | Zähnezahl | Artikel-Nr. (code no.) | Preis | Artikel-Nr. (code no.) | Preis |
|--------|----|----|-----|----------------|------------------------|-------------|------------------------|-------------|
| h10 | h6 | | | (no. of | ohne Spannfläche | Euro / je | mit Spannfläche | Euro / je |
| mm | mm | mm | mm | cutting edges) | without Weldon flat | KF393 - ZX4 | with Weldon flat | KF393 - ZX4 |
| • 3,0 | 3 | 20 | 75 | 3 | KF393030ZX4 | 18,20 | --- | --- |
| • 4,0 | 4 | 25 | 75 | 3 | KF393040ZX4 | 20,40 | --- | --- |
| • 5,0 | 5 | 30 | 75 | 3 | KF393050ZX4 | 22,40 | --- | --- |
| • 6,0 | 6 | 30 | 75 | 3 | KF393060ZX4 | 28,60 | --- | auf Anfrage |
| • 8,0 | 8 | 40 | 100 | 3 | KF393080ZX4 | 32,00 | --- | auf Anfrage |
| • 10,0 | 10 | 40 | 100 | 3 | KF393100ZX4 | 42,00 | --- | auf Anfrage |
| • 12,0 | 12 | 45 | 150 | 3 | KF393120ZX4 | 59,60 | --- | auf Anfrage |
| • 16,0 | 16 | 65 | 150 | 3 | KF393160ZX4 | 104,60 | --- | auf Anfrage |
| • 20,0 | 20 | 65 | 150 | 3 | KF393200ZX4 | 139,00 | --- | auf Anfrage |

VHM-Schaftfräser KF394 Extra Lang - 4-Schneiden - ZX4

| d1 | d2 | l2 | l1 | Zähnezahl | Artikel-Nr. (code no.) | Preis | Artikel-Nr. (code no.) | Preis |
|--------|----|----|-----|----------------|------------------------|-------------|------------------------|-------------|
| h10 | h6 | | | (no. of | ohne Spannfläche | Euro / je | mit Spannfläche | Euro / je |
| mm | mm | mm | mm | cutting edges) | without Weldon flat | KF394 - ZX4 | with Weldon flat | KF394 - ZX4 |
| • 3,0 | 3 | 20 | 75 | 4 | KF394030ZX4 | 14,20 | --- | --- |
| • 4,0 | 4 | 25 | 75 | 4 | KF394040ZX4 | 16,20 | --- | --- |
| • 5,0 | 5 | 30 | 75 | 4 | KF394050ZX4 | 17,40 | --- | --- |
| • 6,0 | 6 | 30 | 75 | 4 | KF394060ZX4 | 21,80 | KF394060WZX4 | 24,00 |
| • 8,0 | 8 | 40 | 100 | 4 | KF394080ZX4 | 27,40 | KF394080WZX4 | 29,80 |
| • 10,0 | 10 | 40 | 100 | 4 | KF394100ZX4 | 33,20 | KF394100WZX4 | 35,60 |
| • 12,0 | 12 | 45 | 150 | 4 | KF394120ZX4 | 51,20 | KF394120WZX4 | 55,80 |
| • 14,0 | 14 | 45 | 150 | 4 | KF394140ZX4 | 62,60 | KF394140WZX4 | 67,20 |
| • 16,0 | 16 | 65 | 150 | 4 | KF394160ZX4 | 83,20 | KF394160WZX4 | 87,80 |
| • 18,0 | 18 | 65 | 150 | 4 | KF394180ZX4 | 99,00 | KF394180WZX4 | 103,60 |
| • 20,0 | 20 | 65 | 150 | 4 | KF394200ZX4 | 112,80 | KF394200WZX4 | 117,40 |

VHM-MINI SCHAFTFRÄSER 45°

KF300 - ZX3



Einsatzgebiete: Universell einsetzbar, sowohl für hochfeste Werkstoffe als auch für Alu und NE-Metalle geeignet.

application: Universal applications. Suitable for high hard materials as well as aluminium and nonferrous metals.

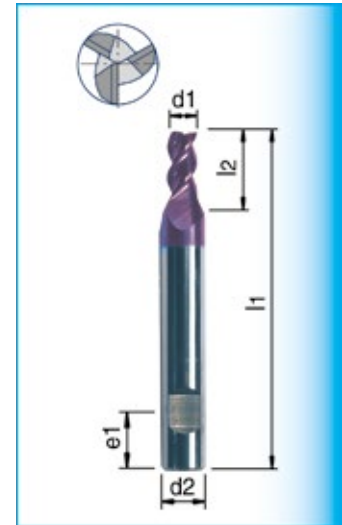

| * Durchmesser-toleranz (Ø-tolerance) „e8“: | | | |
|--|-----------------|----------------|--|
| Ø 2 - Ø 3 | Ø 3 - Ø 6 | Ø 6 - Ø 10 | |
| -0,014 / -0,028 | -0,020 / -0,038 | -0,025 / 0,047 | |



- ab Lager / ex stock
- kurzfristig / on short notice
- Lieferzeit auf Anfrage / delivery time upon request

| | d1 e8* mm | d2 h6 mm | l2 h6 mm | l1 h6 mm | Länge e1 | Artikel-Nr. (code no.) | Preis Euro / je KF300 - ZX3 |
|---|-----------------|----------------|----------------|----------------|----------|---------------------------|-----------------------------------|
| • | 0,5 | 3,0 | 1,5 | 45 | - | KF300005ZX3 | 13,20 |
| • | 1,0 | 3,0 | 2,0 | 45 | - | KF300010ZX3 | 13,20 |
| • | 1,5 | 3,0 | 3,0 | 45 | - | KF300015ZX3 | 13,20 |
| • | 1,8 | 3,0 | 3,0 | 45 | - | KF300018ZX3 | 13,20 |
| • | 2,0 | 6,0 | 4,0 | 45 | 8,0 | KF300020ZX3 | 13,20 |
| • | 2,8 | 6,0 | 6,0 | 45 | 8,0 | KF300028ZX3 | 14,60 |
| • | 3,0 | 6,0 | 6,0 | 45 | 8,0 | KF300030ZX3 | 13,20 |
| • | 3,8 | 6,0 | 7,0 | 45 | 8,0 | KF300038ZX3 | 14,60 |
| • | 4,0 | 6,0 | 7,0 | 45 | 8,0 | KF300040ZX3 | 13,20 |
| • | 4,8 | 6,0 | 8,0 | 45 | 8,0 | KF300048ZX3 | 14,60 |
| • | 5,0 | 6,0 | 8,0 | 45 | 8,0 | KF300050ZX3 | 13,20 |
| • | 5,75 | 6,0 | 10,0 | 45 | 8,0 | KF300057ZX3 | 14,60 |
| • | 6,0 | 6,0 | 10,0 | 45 | 8,0 | KF300060ZX3 | 13,20 |
| • | 6,75 | 8,0 | 10,0 | 55 | 11,0 | KF300067ZX3 | 20,40 |
| • | 7,0 | 8,0 | 12,0 | 55 | 11,0 | KF300070ZX3 | 18,80 |
| • | 7,75 | 8,0 | 12,0 | 55 | 11,0 | KF300077ZX3 | 20,40 |
| • | 8,0 | 8,0 | 13,0 | 55 | 11,0 | KF300080ZX3 | 18,80 |
| • | 8,7 | 10,0 | 14,0 | 55 | 7,0 | KF300087ZX3 | 24,80 |
| • | 9,7 | 10,0 | 16,0 | 55 | 7,0 | KF300097ZX3 | 24,80 |
| • | 10,0 | 10,0 | 16,0 | 55 | 7,0 | KF300100ZX3 | 22,60 |

VHM-SCHLICHTFRÄSER 45°

KF308 / KF309 - ZX3



Einsatzgebiete: Speziell geeignet zum Umfangsfräsen zur Erzeugung höchster Oberflächengüten. Universell einsetzbar, sowohl für hochfeste Werkstoffe als auch für Alu und NE-Metalle geeignet.

application: Well suited for machining of circumference to achieve high surface qualities. Universal use, suited for high-tensile materials as well as for Al and nonferrous materials.

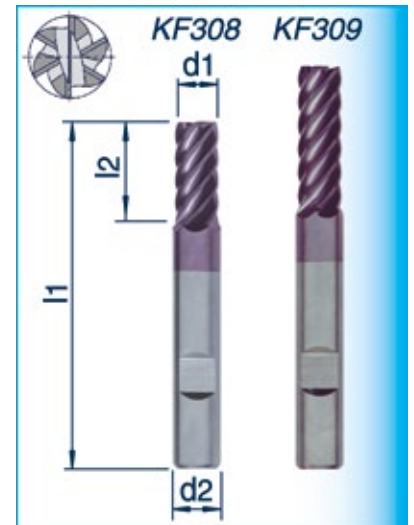

| * Durchmessertoleranz (Ø-tolerance) „f8“: | | | |
|---|-----------------|-----------------|-----------------|
| Ø 3 - Ø 6 | Ø 6 - Ø 10 | Ø 10 - Ø 18 | Ø 18 - Ø 20 |
| -0,010 / -0,028 | -0,013 / -0,035 | -0,016 / -0,043 | -0,020 / -0,053 |



- ab Lager / ex stock
- kurzfristig / on short notice
- Lieferzeit auf Anfrage / delivery time upon request

VHM-Schlichtfräser KF308 DIN 6527 Lang - ZX3

*solange Vorrat

| d1 f8* mm | d2 h6 mm | l2 mm | l1 mm | Zähnezahl (no. of cutting edges) | Artikel-Nr. (code no.) | Preis Euro / je KF308 - ZX3 | |
|-----------------|----------------|----------|----------|--|---------------------------|-----------------------------------|-------|
| *.* | 4,0 | 6,0 | 11,0 | 57,0 | 6 | KF308040ZX3 | 13,80 |
| *.* | 5,0 | 6,0 | 13,0 | 57,0 | 6 | KF308050ZX3 | 13,80 |
| *.* | 6,0 | 6,0 | 13,0 | 57,0 | 6 | KF308060ZX3 | 13,80 |
| *.* | 7,0 | 8,0 | 16,0 | 63,0 | 6 | KF308070ZX3 | 16,20 |
| *.* | 8,0 | 8,0 | 19,0 | 63,0 | 6 | KF308080ZX3 | 16,20 |
| *.* | 9,0 | 10,0 | 19,0 | 72,0 | 6 | KF308090ZX3 | 32,40 |
| *.* | 10,0 | 10,0 | 22,0 | 72,0 | 6 | KF308100ZX3 | 27,80 |
| *.* | 12,0 | 12,0 | 26,0 | 83,0 | 6 | KF308120ZX3 | 32,80 |
| *.* | 14,0 | 14,0 | 26,0 | 83,0 | 6 | KF308140ZX3 | 56,80 |
| *.* | 16,0 | 16,0 | 32,0 | 92,0 | 6 | KF308160ZX3 | 57,20 |
| *.* | 18,0 | 18,0 | 32,0 | 92,0 | 8 | KF308180ZX3 | 87,20 |
| *.* | 20,0 | 20,0 | 38,0 | 104,0 | 8 | KF308200ZX3 | 80,80 |

VHM-Schlichtfräser KF309 EXTRA LANG - ZX3

*solange Vorrat

| d1 f8* mm | d2 h6 mm | l2 mm | l1 mm | Zähnezahl (no. of cutting edges) | Artikel-Nr. (code no.) | Preis Euro / je KF309 - ZX3 | |
|-----------------|----------------|----------|----------|--|---------------------------|-----------------------------------|--------|
| *.* | 4,0 | 6,0 | 16,0 | 62,0 | 6 | KF309040ZX3 | 16,40 |
| *.* | 5,0 | 6,0 | 18,0 | 62,0 | 6 | KF309050ZX3 | 16,40 |
| *.* | 6,0 | 6,0 | 18,0 | 62,0 | 6 | KF309060ZX3 | 16,40 |
| *.* | 7,0 | 8,0 | 21,0 | 68,0 | 6 | KF309070ZX3 | 31,40 |
| *.* | 8,0 | 8,0 | 24,0 | 68,0 | 6 | KF309080ZX3 | 18,80 |
| *.* | 9,0 | 10,0 | 27,0 | 80,0 | 6 | KF309090ZX3 | 49,40 |
| *.* | 10,0 | 10,0 | 30,0 | 80,0 | 6 | KF309100ZX3 | 33,00 |
| *.* | 12,0 | 12,0 | 36,0 | 93,0 | 6 | KF309120ZX3 | 38,80 |
| *.* | 14,0 | 14,0 | 42,0 | 99,0 | 6 | KF309140ZX3 | 88,80 |
| *.* | 16,0 | 16,0 | 48,0 | 108,0 | 6 | KF309160ZX3 | 72,40 |
| *.* | 18,0 | 18,0 | 54,0 | 114,0 | 8 | KF309180ZX3 | 139,80 |
| *.* | 20,0 | 20,0 | 60,0 | 126,0 | 8 | KF309200ZX3 | 100,20 |
| *.* | 25,0 | 25,0 | 95,0 | 160,0 | 8 | KF309250ZX3 | 299,80 |

Weitere lieferbare Ausführungen:

- VHM-Schlichtfräser mit Eckenradius
- VHM-Schlichtfräser mit abgesetztem Schaft (Halseinschliff)
- andere Durchmesser und Längen auf Anfrage

VHM-ALU-FRÄSER 45° kurz / lang / extra lang

KF302 / KF396

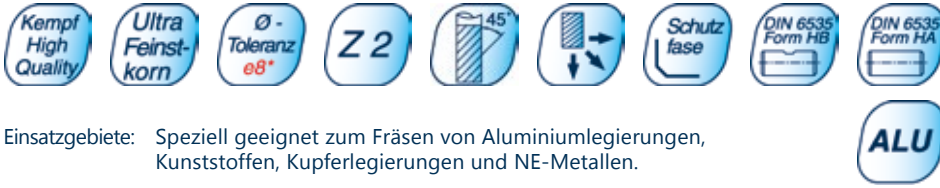

Einsatzgebiete: Speziell geeignet zum Fräsen von Aluminiumlegierungen, Kunststoffen, Kupferlegierungen und NE-Metallen.

application: Especially suited for milling of aluminium alloys, plastics, copper alloys and non-ferrous metals.

| * Durchmesser-toleranz (Ø-tolerance) „e8“: | | | | | Schutzfase / protection chamfer | | | |
|--|-----------------|-----------------|-----------------|-----------------|---------------------------------|------------|------------|-------------|
| Ø 2 - Ø 3 | Ø 3 - Ø 6 | Ø 6 - Ø 10 | Ø 10 - Ø 18 | Ø 18 - Ø 20 | Ø 2 - Ø 6 | Ø 8 - Ø 10 | Ø 12 | Ø 14 - Ø 20 |
| -0,014 / -0,028 | -0,020 / -0,038 | -0,025 / -0,047 | -0,032 / -0,059 | -0,040 / -0,073 | 0,03 -0,02 | 0,05 -0,02 | 0,10 -0,02 | 0,10 ±0,02 |

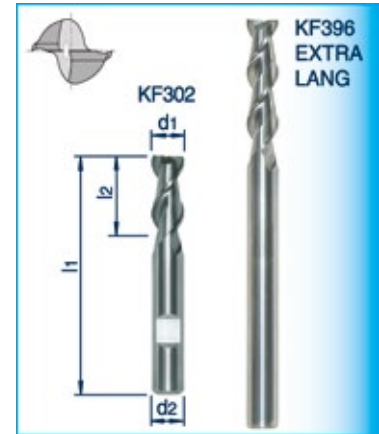

- ab Lager / ex stock
- kurzfristig / on short notice
- Lieferzeit auf Anfrage / delivery time upon request

VHM-ALU-FRÄSER Typ KF302 kurz/lang - Schaft DIN 6535 Form HB

| d1 e8* mm | d2 h6 mm | l2 mm | l1 mm | Zähnezahl (no. of cutting edges) | Artikel-Nr. (code no.) | Preis Euro / je KF302 ALU |
|-----------------|----------------|----------|----------|--|---------------------------|---------------------------------|
| • 3,0 | 6,0 | 4,0 | 50,0 | 2 | KF302030ALUK | 8,80 |
| • 3,0 | 6,0 | 7,0 | 57,0 | 2 | KF302030ALUL | 10,60 |
| • 4,0 | 6,0 | 5,0 | 54,0 | 2 | KF302040ALUK | 8,80 |
| • 4,0 | 6,0 | 8,0 | 57,0 | 2 | KF302040ALUL | 10,60 |
| • 5,0 | 6,0 | 6,0 | 54,0 | 2 | KF302050ALUK | 8,80 |
| • 5,0 | 6,0 | 10,0 | 57,0 | 2 | KF302050ALUL | 10,60 |
| • 6,0 | 6,0 | 7,0 | 54,0 | 2 | KF302060ALUK | 8,80 |
| • 6,0 | 6,0 | 10,0 | 57,0 | 2 | KF302060ALUL | 10,60 |
| • 8,0 | 8,0 | 9,0 | 58,0 | 2 | KF302080ALUK | 10,20 |
| • 8,0 | 8,0 | 16,0 | 63,0 | 2 | KF302080ALUL | 12,00 |
| • 10,0 | 10,0 | 11,0 | 66,0 | 2 | KF302100ALUK | 13,60 |
| • 10,0 | 10,0 | 19,0 | 72,0 | 2 | KF302100ALUL | 20,80 |
| • 12,0 | 12,0 | 12,0 | 73,0 | 2 | KF302120ALUK | 20,80 |
| • 12,0 | 12,0 | 22,0 | 83,0 | 2 | KF302120ALUL | 30,00 |
| • 14,0 | 14,0 | 14,0 | 75,0 | 2 | KF302140ALUK | 27,40 |
| • 14,0 | 14,0 | 22,0 | 83,0 | 2 | KF302140ALUL | 36,00 |
| • 16,0 | 16,0 | 16,0 | 82,0 | 2 | KF302160ALUK | 31,60 |
| • 16,0 | 16,0 | 26,0 | 92,0 | 2 | KF302160ALUL | 49,60 |
| • 18,0 | 18,0 | 18,0 | 84,0 | 2 | KF302180ALUK | 41,40 |
| • 18,0 | 18,0 | 26,0 | 92,0 | 2 | KF302180ALUL | 56,00 |
| • 20,0 | 20,0 | 20,0 | 92,0 | 2 | KF302200ALUK | 54,80 |
| • 20,0 | 20,0 | 32,0 | 104,0 | 2 | KF302200ALUL | 76,60 |

VHM-ALU-FRÄSER Typ KF396 EXTRA LANG - Schaft DIN 6535 Form HA

| d1 h10 mm | d2 h6 mm | l2 mm | l1 mm | Zähnezahl (no. of cutting edges) | Artikel-Nr. (code no.) | Preis Euro / je KF396 ALU |
|-----------------|----------------|----------|----------|--|---------------------------|---------------------------------|
| • 5,0 | 5,0 | 30 | 75 | 2 | KF396050ALU | 17,20 |
| • 6,0 | 6,0 | 30 | 75 | 2 | KF396060ALU | 23,40 |
| • 8,0 | 8,0 | 40 | 100 | 2 | KF396080ALU | 28,20 |
| • 10,0 | 10,0 | 40 | 100 | 2 | KF396100ALU | 39,60 |
| • 12,0 | 12,0 | 45 | 150 | 2 | KF396120ALU | 62,20 |
| • 16,0 | 16,0 | 65 | 150 | 2 | KF396160ALU | 114,40 |

VHM-ALU-SCHRUPPFRÄSER

KF312 / KF313-(mit IK)



Einsatzgebiete: Speziell geeignet zum Fräsen von Aluminiumlegierungen, Kupferlegierungen, Kunststoffen und NE-Metallen.

application: Especially suited for milling of aluminium alloys, plastics, copper alloys and non-ferrous metals.

KF312 = ALU-Schruppfräser ohne Innenkühlung / end mill for AL without inner coolant supply

KF313 = ALU-Schruppfräser mit Innenkühlung / end mill for AL with inner coolant supply

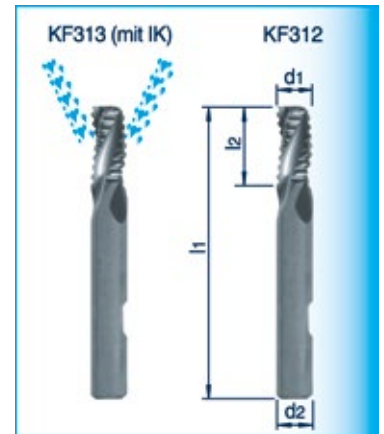

- ab Lager / ex stock
- kurzfristig / on short notice
- Lieferzeit auf Anfrage / delivery time upon request

| d1 h10 mm | d2 h6 mm | l2 mm | l1 mm | Artikel-Nr. (code no.) ohne Innenkühlung without inner coolant | Preis Euro / je ohne Innenkühlung without inner coolant | Artikel-Nr. (code no.) mit Innenkühlung with inner coolant | Preis Euro / je mit Innenkühlung with inner coolant |
|-----------------|----------------|----------|----------|---|--|---|--|
| • 6,0 | 6,0 | 10 | 57 | KF312060ALU | 22,20 | KF313060ALU | 31,00 |
| • 8,0 | 8,0 | 16 | 63 | KF312080ALU | 23,00 | KF313080ALU | 35,00 |
| • 10,0 | 10,0 | 19 | 72 | KF312100ALU | 28,20 | KF313100ALU | 38,20 |
| • 12,0 | 12,0 | 22 | 83 | KF312120ALU | 34,60 | KF313120ALU | 53,60 |
| • 16,0 | 16,0 | 26 | 92 | KF312160ALU | 52,60 | KF313160ALU | 78,00 |
| • 20,0 | 20,0 | 32 | 104 | KF312200ALU | 99,00 | KF313200ALU | 134,20 |

VHM-ALU-FRÄSER mit Innenkühlung

KF318



Einsatzgebiete: Speziell zum Fräsen von Aluminiumlegierungen, Kunststoffen, Kupferlegierungen und NE-Metallen.

application: Especially suited for milling of aluminium alloys, plastics, copper alloys and non-ferrous metals.

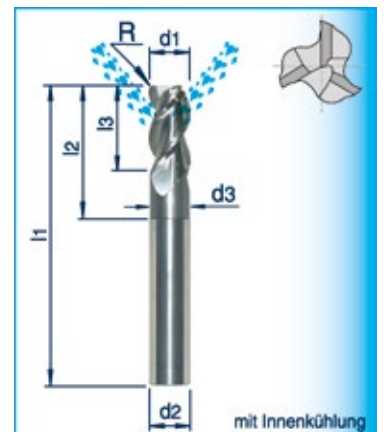

- ab Lager / ex stock
- kurzfristig / on short notice
- Lieferzeit auf Anfrage / delivery time upon request

| d1 h10 mm | Radius R mm | d2 h6 mm | d3 mm | l1 mm | l2 mm | l3 mm | Zähnezahl (no. of cutting edges) | Artikel-Nr. (code no.) | Preis Euro / je KF318 |
|-----------------|-------------------|----------------|----------|----------|----------|----------|--|---------------------------|-----------------------------|
| • 6,0 | 1,0 | 6,0 | 5,7 | 57,0 | 21,0 | 10,0 | 3 | KF318060ALU | 17,80 |
| • 8,0 | 1,0 | 8,0 | 7,7 | 63,0 | 27,0 | 16,0 | 3 | KF318080ALU | 19,80 |
| • 10,0 | 1,5 | 10,0 | 9,5 | 72,0 | 32,0 | 19,0 | 3 | KF318100ALU | 35,20 |
| • 12,0 | 1,5 | 12,0 | 11,5 | 83,0 | 38,0 | 22,0 | 3 | KF318120ALU | 52,60 |
| • 16,0 | 2,0 | 16,0 | 15,5 | 92,0 | 44,0 | 26,0 | 3 | KF318160ALU | 84,20 |
| • 20,0 | 2,5 | 20,0 | 19,5 | 104,0 | 54,0 | 32,0 | 3 | KF318200ALU | 120,20 |

VHM-HSC-EINZAHNFRÄSER

KF535



Einsatzgebiete: Einzahnfräser mit geläppter Spannutt und extrem scharfer Schneide zur Bearbeitung von Aluminium und Kunststoff. Geläppte Spannutt mit niedrigem Reibungskoeffizient und extrem begünstigtem Spanabfluss.

application: Single cutting edge end mill with lapped chip flute and extremely sharp cutting edge to machine aluminium and plastics. Lapped chip flute with low friction coefficient supports chip removal.



Hinweis: Einzahnfräser sind auch mit Linksdraht (rechtsschneidend) ohne Aufpreis kurzfristig lieferbar.
Note: These end mills are also available with lefthand-twist (RH-cutting) on short notice at no surcharge.

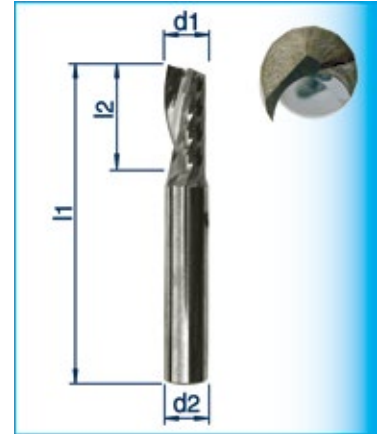

- ab Lager / ex stock
- kurzfristig / on short notice
- Lieferzeit ca. 1-2 Wochen / delivery time approx. 1-2 weeks

VHM-HSC-Einzahnfräser mit geläppter Spannutt

| | d1 h10 mm | d2 h6 mm | l1 mm | l2 mm | Zähnezahl (no. of cutting edges) | Artikel-Nr. (code no.) | Preis Euro / je KF535 |
|---|-----------------|----------------|----------|----------|--|---------------------------|-----------------------------|
| • | 2,0 | 2,0 | 40,0 | 10,0 | 1 | KF535020 | 9,00 |
| • | 3,0 | 3,0 | 40,0 | 12,0 | 1 | KF535030 | 9,60 |
| • | 4,0 | 4,0 | 40,0 | 15,0 | 1 | KF535040 | 11,60 |
| • | 5,0 | 5,0 | 50,0 | 16,0 | 1 | KF535050 | 15,00 |
| • | 6,0 | 6,0 | 60,0 | 20,0 | 1 | KF535060 | 17,20 |
| • | 8,0 | 8,0 | 63,0 | 22,0 | 1 | KF535080 | 27,60 |
| • | 10,0 | 10,0 | 72,0 | 25,0 | 1 | KF535100 | 41,60 |
| • | 12,0 | 12,0 | 83,0 | 30,0 | 1 | KF535120 | 55,00 |
| • | 14,0 | 14,0 | 83,0 | 30,0 | 1 | KF535140 | 82,40 |
| • | 16,0 | 16,0 | 92,0 | 35,0 | 1 | KF535160 | 116,80 |
| • | 18,0 | 18,0 | 92,0 | 35,0 | 1 | KF535180 | 139,80 |
| • | 20,0 | 20,0 | 104,0 | 40,0 | 1 | KF535200 | 157,00 |

VHM-HSC-Einzahnfräser mit geläppter Spannutt und verstärktem Schaft

| | d1 h10 mm | d2 h6 mm | l1 mm | l2 mm | Zähnezahl (no. of cutting edges) | Artikel-Nr. (code no.) | Preis Euro / je KF535 |
|---|-----------------|----------------|----------|----------|--|---------------------------|-----------------------------|
| • | 1,0 | 6,0 | 50,0 | 4,0 | 1 | KF535010V | 20,60 |
| • | 2,0 | 6,0 | 50,0 | 6,0 | 1 | KF535020V1 | 20,60 |
| • | 2,0 | 6,0 | 50,0 | 20,0 | 1 | KF535020V2 | 21,60 |
| • | 3,0 | 6,0 | 50,0 | 11,0 | 1 | KF535030V1 | 20,60 |
| • | 3,0 | 6,0 | 50,0 | 22,0 | 1 | KF535030V2 | 21,60 |
| • | 4,0 | 6,0 | 50,0 | 14,0 | 1 | KF535040V1 | 20,60 |
| • | 4,0 | 6,0 | 50,0 | 22,0 | 1 | KF535040V2 | 21,60 |
| • | 5,0 | 6,0 | 50,0 | 22,0 | 1 | KF535050V | 21,60 |
| • | 6,0 | 6,0 | 50,0 | 22,0 | 1 | KF535060V | 21,60 |

VHM-HSC-Micro-Einzahnfräser mit geläppter Spannutt und verstärktem Schaft

| | d1 h10 mm | d2 h6 mm | l1 mm | l2 mm | Zähnezahl (no. of cutting edges) | Artikel-Nr. (code no.) | Preis Euro / je KF535 |
|---|-----------------|----------------|----------|----------|--|---------------------------|-----------------------------|
| • | 0,5 | 3,0 | 39,0 | 1,5 | 1 | KF535005M | 13,80 |
| • | 0,6 | 3,0 | 39,0 | 1,5 | 1 | KF535006M | 13,80 |
| • | 0,8 | 3,0 | 39,0 | 2,0 | 1 | KF535008M | 15,00 |
| • | 1,0 | 3,0 | 39,0 | 3,0 | 1 | KF535010M | 13,80 |
| • | 1,2 | 3,0 | 39,0 | 4,0 | 1 | KF535012M | 13,80 |
| • | 1,4 | 3,0 | 39,0 | 4,0 | 1 | KF535014M | 15,00 |
| • | 1,5 | 3,0 | 39,0 | 4,0 | 1 | KF535015M | 15,00 |
| • | 1,6 | 3,0 | 39,0 | 4,0 | 1 | KF535016M | 15,60 |
| • | 1,8 | 3,0 | 39,0 | 5,0 | 1 | KF535018M | 15,60 |
| • | 2,0 | 3,0 | 39,0 | 5,0 | 1 | KF535020M | 15,00 |
| • | 2,5 | 3,0 | 39,0 | 7,0 | 1 | KF535025M | 16,60 |
| • | 3,0 | 3,0 | 39,0 | 10,0 | 1 | KF535030M | 19,60 |

VHM-HSC-SCHAFTFRÄSER mit geläppter Spannutt

KF536



Einsatzgebiete: Schaftfräser mit geläppter Spannutt und extrem scharfer Schneide zur Bearbeitung von Aluminium und Kunststoff. Geläppte Spannutt mit niedrigem Reibungskoeffizient und extrem begünstigtem Spanabfluss.

application: Single cutting edge end mill with lapped chip flute and extremely sharp cutting edge to machine aluminium and plastics. Lapped chip flute with low friction coefficient supports chip removal.

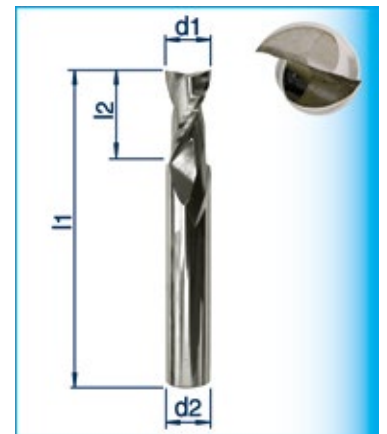

- ab Lager / ex stock
- kurzfristig / on short notice
- Lieferzeit ca. 1-2 Wochen / delivery time approx. 1-2 weeks

| d1 h10 mm | d2 h6 mm | l1 mm | l2 mm | Zähnezahl (no. of cutting edges) | Artikel-Nr. (code no.) | Preis Euro / je KF536 |
|-----------------|----------------|----------|----------|--|---------------------------|-----------------------------|
| • 3,0 | 3,0 | 40,0 | 12,0 | 2 | KF536030 | 12,00 |
| • 4,0 | 4,0 | 40,0 | 14,0 | 2 | KF536040 | 13,00 |
| • 5,0 | 5,0 | 50,0 | 16,0 | 2 | KF536050 | 15,00 |
| • 6,0 | 6,0 | 50,0 | 18,0 | 2 | KF536060 | 19,20 |
| • 8,0 | 8,0 | 63,0 | 20,0 | 2 | KF536080 | 28,60 |
| • 10,0 | 10,0 | 72,0 | 25,0 | 2 | KF536100 | 38,20 |
| • 12,0 | 12,0 | 83,0 | 30,0 | 2 | KF536120 | 52,40 |
| • 16,0 | 16,0 | 92,0 | 35,0 | 2 | KF536160 | 111,20 |
| • 20,0 | 20,0 | 104,0 | 45,0 | 2 | KF536200 | 157,00 |

VHM-HSC-SCHAFTFRÄSER mit geläppter Spannutt

KF537



Einsatzgebiete: Schaftfräser mit geläppter Spannutt und extrem scharfer Schneide zur Bearbeitung von Aluminium und Kunststoff. Geläppte Spannutt mit niedrigem Reibungskoeffizient und extrem begünstigtem Spanabfluss.

application: Single cutting edge end mill with lapped chip flute and extremely sharp cutting edge to machine aluminium and plastics. Lapped chip flute with low friction coefficient supports chip removal.

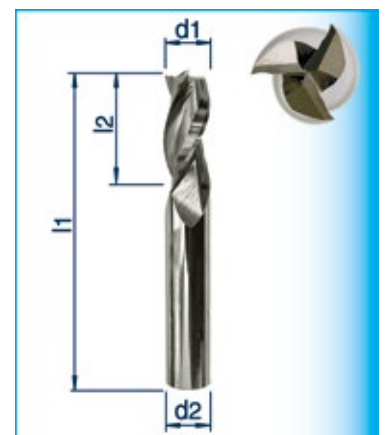

- ab Lager / ex stock
- kurzfristig / on short notice
- Lieferzeit ca. 1-2 Wochen / delivery time approx. 1-2 weeks

| d1 h10 mm | d2 h6 mm | l1 mm | l2 mm | Zähnezahl (no. of cutting edges) | Artikel-Nr. (code no.) | Preis Euro / je KF537 |
|-----------------|----------------|----------|----------|--|---------------------------|-----------------------------|
| • 3,0 | 3,0 | 40,0 | 12,0 | 3 | KF537030 | 13,20 |
| • 4,0 | 4,0 | 40,0 | 14,0 | 3 | KF537040 | 14,40 |
| • 5,0 | 5,0 | 50,0 | 16,0 | 3 | KF537050 | 16,40 |
| • 6,0 | 6,0 | 50,0 | 18,0 | 3 | KF537060 | 20,80 |
| • 8,0 | 8,0 | 63,0 | 20,0 | 3 | KF537080 | 30,00 |
| • 10,0 | 10,0 | 72,0 | 25,0 | 3 | KF537100 | 40,20 |
| • 12,0 | 12,0 | 83,0 | 30,0 | 3 | KF537120 | 55,00 |
| • 16,0 | 16,0 | 92,0 | 35,0 | 3 | KF537160 | 116,80 |
| • 20,0 | 20,0 | 104,0 | 45,0 | 3 | KF537200 | 165,00 |

VHM-HSC-SCHAFTFRÄSER Diamantverzahnt/Stirnverzahnt KF630



Einsatzgebiete: Schafffräser mit Diamantverzahnung und mehrschneidiger Stirnverzahnung zur Bearbeitung von Faserkunststoffen und Schaumwerkstoffen.

application: End mill with diamond-cut and multiple end cut. To machine fiber plastics and foam materials.



Diamant-beschichtete Vollhartmetallfräser sind auch in anderen Längen und Durchmessern erhältlich.
Diamond-coated solid carbide end mills are available with other lengths and diameters upon request.



- ab Lager / ex stock
- kurzfristig / on short notice
- Lieferzeit auf Anfrage / delivery time upon request

| | d1 h10 mm | d2 h6 mm | l1 mm | l2 mm | Artikel-Nr. (code no.) | Preis Euro / je KF630 |
|---|-----------------|----------------|----------|----------|---------------------------|-----------------------------|
| • | 3,0 | 3,0 | 40 | 10 | KF630030 | 10,60 |
| • | 4,0 | 4,0 | 40 | 15 | KF630040 | 13,00 |
| • | 5,0 | 5,0 | 50 | 16 | KF630050 | 17,20 |
| • | 6,0 | 6,0 | 50 | 18 | KF630060 | 19,00 |
| • | 8,0 | 8,0 | 63 | 25 | KF630080 | 28,40 |
| • | 10,0 | 10,0 | 72 | 30 | KF630100 | 39,40 |
| • | 12,0 | 12,0 | 82 | 32 | KF630120 | 55,60 |

Hinweis: Diese Fräser erhalten Sie auch mit einer Diamantbeschichtung (für Graphitbearbeitung).
Note: Also available with diamond coating on short notice (to machine graphite).

VHM-HSC-SCHAFTFRÄSER Diamantverzahnt/Stirnschnitt für Nuten KF631



Einsatzgebiete: Nutfräser mit Diamantverzahnung und zweischneidiger Stirnverzahnung zur Bearbeitung von Faserkunststoffen und Schaumwerkstoffen.

application: Groove mill with diamond cut and double front-cut to machine fiber plastics and foam materials.



Diamant-beschichtete Vollhartmetallfräser sind auch in anderen Längen und Durchmessern erhältlich.
Diamond-coated solid carbide end mills are available with other lengths and diameters upon request.



- ab Lager / ex stock
- kurzfristig / on short notice
- Lieferzeit auf Anfrage / delivery time upon request

| | d1 h10 mm | d2 h6 mm | l1 mm | l2 mm | Artikel-Nr. (code no.) | Preis Euro / je KF631 |
|---|-----------------|----------------|----------|----------|---------------------------|-----------------------------|
| • | 2,0 | 2,0 | 40 | 7,0 | KF631020 | 11,60 |
| • | 3,0 | 3,0 | 40 | 10,0 | KF631030 | 11,60 |
| • | 4,0 | 4,0 | 40 | 15,0 | KF631040 | 14,00 |
| • | 5,0 | 5,0 | 50 | 16,0 | KF631050 | 18,60 |
| • | 6,0 | 6,0 | 50 | 18,0 | KF631060 | 20,40 |
| • | 8,0 | 8,0 | 63 | 25,0 | KF631080 | 30,60 |
| • | 10,0 | 10,0 | 72 | 30,0 | KF631100 | 41,80 |
| • | 12,0 | 12,0 | 82,0 | 32,0 | KF631120 | 58,60 |

VHM-HSC-SCHAFTFRÄSER Diamantverzahnt/Bohrerspizze 135° KF632



Einsatzgebiete: Schaftfräser mit Diamantverzahnung und Bohrerspizze zur Bearbeitung von Faserkunststoffen und Schaumwerkstoffen.

application: End mill with diamond-cut and drill tip to machine fiber plastics and foam materials.



Diamant-beschichtete Vollhartmetallfräser sind auch in anderen Längen und Durchmessern erhältlich.
Diamond-coated solid carbide end mills are available with other lengths and diameters upon request.

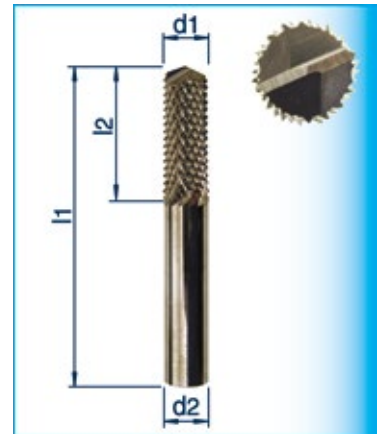

- ab Lager / ex stock
- kurzfristig / on short notice
- Lieferzeit auf Anfrage / delivery time upon request

| | d1 h10 mm | d2 h6 mm | l1 mm | l2 mm | Artikel-Nr. (code no.) | Preis Euro / je KF632 |
|---|-----------------|----------------|----------|----------|---------------------------|-----------------------------|
| • | 3,0 | 3,0 | 40 | 10,0 | KF632030 | 12,40 |
| • | 3,5 | 3,5 | 40 | 12,0 | KF632035 | 13,60 |
| • | 4,0 | 4,0 | 40 | 15,0 | KF632040 | 14,40 |
| • | 5,0 | 5,0 | 50 | 16,0 | KF632050 | 19,60 |
| • | 6,0 | 6,0 | 50 | 18,0 | KF632060 | 21,00 |
| • | 8,0 | 8,0 | 63 | 25,0 | KF632080 | 31,00 |
| • | 10,0 | 10,0 | 72 | 30,0 | KF632100 | 42,40 |
| • | 12,0 | 12,0 | 82 | 32,0 | KF632120 | 59,80 |

Hinweis: Diese Fräser erhalten Sie auch mit einer Diamantbeschichtung (für Graphitbearbeitung).
Note: Also available with diamond coating on short notice (to machine graphite).

Info zu Fräserarten mit Pyramidenverzahnung / Diamantverzahnung

Diese Fräser werden in einem speziellen Schleifverfahren hergestellt. Es führt zu höchster Fertigungsqualität und kombiniert zwei wichtige Charakteristiken:

- polierte Spannuten und scharfe Schneidkanten

Hierdurch werden beim Werkzeug folgende Eigenschaften erreicht:

- geringer Reibungskoeffizient
- bessere Spanabfuhr
- hohe Schnitthaltigkeit
- hohe Werkzeuglebensdauer



Info zu Fräserarten mit Pyramidenverzahnung / Diamantverzahnung

Typ KF630 - mit mehrschneidiger Stirnverzahnung
Stirnfräsen / Umfangsfräsen / Besäumen



Typ KF631 - mit zweischneidiger Stirnverzahnung
Tauchen / Nutfräsen / Umfangsfräsen



Typ KF632 - mit Bohrerspizze 135°
Bohren / Zuschneiden / Besäumen



PKD-SCHAFTFRÄSER mit Innenkühlung Achswinkel neutral KF910



Einsatzgebiete: Für die Bearbeitung von NE-Metallen wie Aluminium, Messing, Bronze, Kupfer, GFK, CFK, Graphit und Kohlenstoffe, Duroplaste und Thermoplaste.

application: For machining of non-ferrous metals such as aluminium, brass, bronze, copper, GRP and CFK, graphite and carbons, curable and thermo plastics.



- ab Lager / ex stock
- kurzfristig / on short notice
- Lieferzeit auf Anfrage / delivery time upon request

Hinweis: Auch mit 3D-Spanleitstufe lieferbar!

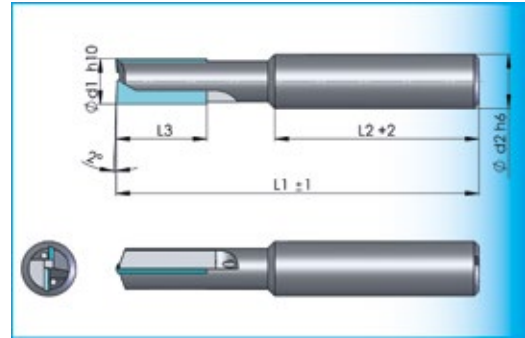

| | d1 h10 mm | d2 h6 mm | l1 Gesamtlänge mm | l2 Schaftlänge mm | l3 (PKD-Länge) mm | Artikel-Nr. (code no.) | Preis Euro / je KF910 |
|---|-----------------|----------------|-------------------------|-------------------------|-------------------------|---------------------------|-----------------------------|
| • | 6 | 8 | 60 | 36 | 10 | KF9100601 | 137,00 |
| • | 6 | 8 | 80 | 36 | 20 | KF9100602 | 196,00 |
| • | 8 | 10 | 60 | 40 | 10 | KF9100801 | 140,80 |
| • | 8 | 10 | 80 | 40 | 20 | KF9100802 | 222,20 |
| • | 10 | 12 | 70 | 45 | 10 | KF9101001 | 152,00 |
| • | 10 | 12 | 90 | 45 | 20 | KF9101002 | 228,80 |
| • | 12 | 14 | 70 | 45 | 10 | KF9101201 | 171,80 |
| • | 12 | 14 | 90 | 45 | 20 | KF9101202 | 253,00 |
| • | 14 | 16 | 80 | 48 | 10 | KF9101401 | 202,60 |
| • | 14 | 16 | 100 | 48 | 20 | KF9101402 | 290,60 |
| • | 16 | 16 | 90 | 48 | 10 | KF9101601 | 226,60 |
| • | 16 | 16 | 110 | 48 | 20 | KF9101602 | 317,00 |
| • | 18 | 20 | 100 | 50 | 10 | KF9101801 | 255,20 |
| • | 18 | 20 | 120 | 50 | 20 | KF9101802 | 356,60 |
| • | 20 | 20 | 140 | 50 | 10 | KF9102001 | 284,00 |
| • | 20 | 20 | 150 | 50 | 20 | KF9102002 | 391,80 |

PKD-SCHAFTFRÄSER mit Innenkühlung Achswinkel positiv KF915



Einsatzgebiete: Für die Bearbeitung von NE-Metallen wie Aluminium, Messing, Bronze, Kupfer, GFK, CFK, Graphit und Kohlenstoffe, Duroplaste und Thermoplaste.

application: For machining of non-ferrous metals such as aluminium, brass, bronze, copper, GRP and CFK, graphite and carbons, curable and thermo plastics.



- Lieferzeit ca. 4-5 Wochen (approx. 4-5 weeks delivery)
- Mindestabnahme 3 Stk (minimum order quantity 3 pcs)

Hinweis: Auch mit 3D-Spanleitstufe lieferbar!

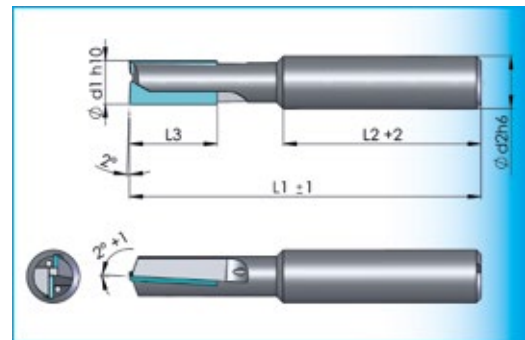

| | d1 h10 mm | d2 h6 mm | l1 Gesamtlänge mm | l2 Schaftlänge mm | l3 (PKD-Länge) mm | Artikel-Nr. (code no.) | Preis Euro / je KF915 |
|---|-----------------|----------------|-------------------------|-------------------------|-------------------------|---------------------------|-----------------------------|
| • | 6 | 8 | 60 | 36 | 10 | KF9150601 | 137,00 |
| • | 6 | 8 | 80 | 36 | 20 | KF9150602 | 196,00 |
| • | 8 | 10 | 60 | 40 | 10 | KF9150801 | 140,80 |
| • | 8 | 10 | 80 | 40 | 20 | KF9150802 | 222,20 |
| • | 10 | 12 | 70 | 45 | 10 | KF9151001 | 152,00 |
| • | 10 | 12 | 90 | 45 | 20 | KF9151002 | 228,80 |
| • | 12 | 14 | 70 | 45 | 10 | KF9151201 | 171,80 |
| • | 12 | 14 | 90 | 45 | 20 | KF9151202 | 253,00 |
| • | 14 | 16 | 80 | 48 | 10 | KF9151401 | 202,60 |
| • | 14 | 16 | 100 | 48 | 20 | KF9151402 | 290,60 |
| • | 16 | 16 | 90 | 48 | 10 | KF9151601 | 226,60 |
| • | 16 | 16 | 110 | 48 | 20 | KF9151602 | 317,00 |
| • | 18 | 20 | 100 | 50 | 10 | KF9151801 | 255,20 |
| • | 18 | 20 | 120 | 50 | 20 | KF9151802 | 356,60 |
| • | 20 | 20 | 140 | 50 | 10 | KF9152001 | 284,00 |
| • | 20 | 20 | 150 | 50 | 20 | KF9152002 | 391,80 |

PKD-SCHAFTFRÄSER mit Innenkühlung Achswinkel negativ KF920



Einsatzgebiete: Für die Bearbeitung von NE-Metallen wie Aluminium, Messing, Bronze, Kupfer, GFK, CFK, Graphit und Kohlenstoffe, Duroplaste und Thermoplaste.

application: For machining of non-ferrous metals such as aluminium, brass, bronze, copper, GRP and CFK, graphite and carbons, curable and thermo plastics.



- Lieferzeit ca. 4-5 Wochen (approx. 4-5 weeks delivery)
- Mindestabnahme 3 Stk (minimum order quantity 3 pcs)

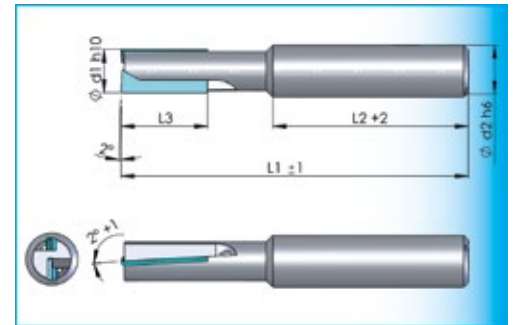

Hinweis: Auch mit 3D-Spanleitstufe lieferbar !

| | d1 h10 mm | d2 h6 mm | l1 Gesamtlänge mm | l2 Schaftlänge mm | l3 (PKD-Länge) mm | Artikel-Nr. (code no.) | Preis Euro / je KF920 |
|---|-----------------|----------------|-------------------------|-------------------------|-------------------------|---------------------------|-----------------------------|
| • | 6 | 8 | 60 | 36 | 10 | KF9200601 | 137,00 |
| • | 6 | 8 | 80 | 36 | 20 | KF9200602 | 196,00 |
| • | 8 | 10 | 60 | 40 | 10 | KF9200801 | 140,80 |
| • | 8 | 10 | 80 | 40 | 20 | KF9200802 | 222,20 |
| • | 10 | 12 | 70 | 45 | 10 | KF9201001 | 152,00 |
| • | 10 | 12 | 90 | 45 | 20 | KF9201002 | 228,80 |
| • | 12 | 14 | 70 | 45 | 10 | KF9201201 | 171,80 |
| • | 12 | 14 | 90 | 45 | 20 | KF9201202 | 253,00 |
| • | 14 | 16 | 80 | 48 | 10 | KF9201401 | 202,60 |
| • | 14 | 16 | 100 | 48 | 20 | KF9201402 | 290,60 |
| • | 16 | 16 | 90 | 48 | 10 | KF9201601 | 226,60 |
| • | 16 | 16 | 110 | 48 | 20 | KF9201602 | 317,00 |
| • | 18 | 20 | 100 | 50 | 10 | KF9201801 | 255,20 |
| • | 18 | 20 | 120 | 50 | 20 | KF9201802 | 356,60 |
| • | 20 | 20 | 140 | 50 | 10 | KF9202001 | 284,00 |
| • | 20 | 20 | 150 | 50 | 20 | KF9202002 | 391,80 |

PKD-RADIUSFRÄSER mit Innenkühlung Achswinkel neutral KFB910



Einsatzgebiete: Für die Bearbeitung von NE-Metallen wie Aluminium, Messing, Bronze, Kupfer, GFK, CFK, Graphit und Kohlenstoffe, Duroplaste und Thermoplaste.

application: For machining of non-ferrous metals such as aluminium, brass, bronze, copper, GRP and CFK, graphite and carbons, curable and thermo plastics.



- ab Lager / ex stock
- kurzfristig / on short notice
- Lieferzeit auf Anfrage / delivery time upon request

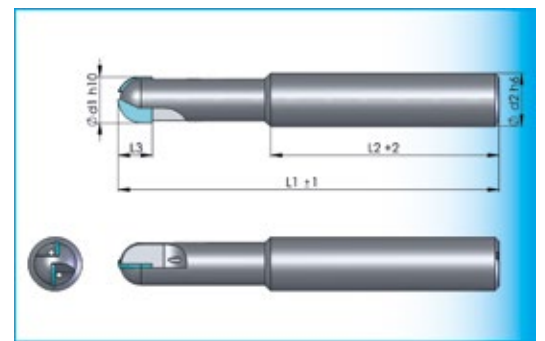

Hinweis: Auch mit 3D-Spanleitstufe lieferbar !

| | d1 h10 mm | d2 h6 mm | l1 Gesamtlänge mm | l2 Schaftlänge mm | l3 (PKD-Länge) mm | Artikel-Nr. (code no.) | Preis Euro / je KF910 |
|---|-----------------|----------------|-------------------------|-------------------------|-------------------------|---------------------------|-----------------------------|
| • | 4 | 6 | 75 | 40 | 2,5 | KFB910040 | 116,60 |
| • | 5 | 8 | 75 | 40 | 3 | KFB910050 | 118,80 |
| • | 6 | 8 | 100 | 60 | 6 | KFB910060 | 149,80 |
| • | 8 | 10 | 100 | 60 | 7 | KFB910080 | 163,00 |
| • | 10 | 12 | 100 | 60 | 8 | KFB910100 | 191,60 |
| • | 12 | 14 | 100 | 60 | 9 | KFB910120 | 224,40 |
| • | 16 | 16 | 150 | 100 | 11 | KFB910160 | 286,20 |
| • | 20 | 20 | 150 | 90 | 13 | KFB910200 | 387,40 |

Vorteile von PKD-Fräsern mit gelasertter 3D-Spanleitstufe:



- geringere Schnittkräfte
- reduzierte Erwärmung am Bauteil
- verringerte Aufbauschneidenbildung
- kurze Späne durch gezielten Spanbruch
- weicherer Schnitt und bessere Oberflächengüten
- längere Standzeiten durch reduzierte Gratbildung

VHM-SCHAFTFRÄSER MIT ECKENRADIUS

KF700 - DIAMANT



Einsatzgebiete: Mit Diamant-Beschichtung zur Bearbeitung von stark abrasiven Werkstoffen. Insbesondere für Graphit, AlSi-Legierungen (Si>10%) und faserverstärkten Werkstoffen. Ausführung mit abgesetztem Halseinschliff (d3) sowie Eckenradius.

application: Diamond-coated to machine very abrasive materials. Especially suited for graphite, AlSi-alloys (Si>10%) and fiber-reinforced materials. With reduced shank (d3) and edge radius.



Diamant-beschichtete Vollhartmetallfräser sind auch in anderen Längen und Durchmessern erhältlich.
Diamond-coated solid carbide end mills are available with other lengths and diameters upon request.

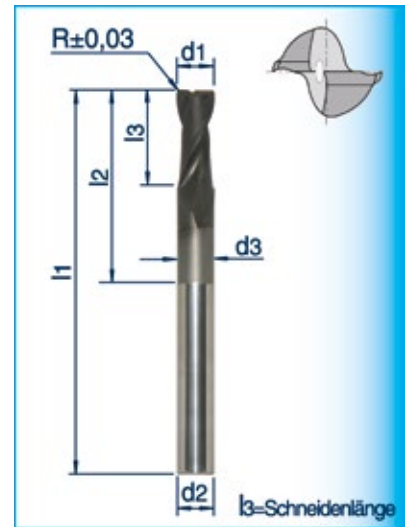

- ab Lager / ex stock
- kurzfristig / on short notice
- Lieferzeit ca. 1-2 Wochen / delivery time approx. 1-2 weeks

| | d1 h10 mm | d2 h6 mm | Radius R ±0,03 | d3 mm | l1 mm | l2 mm | l3 mm | Zähnezahl (no. of cutting edges) | Artikel-Nr. (code no.) | Preis Euro / je KF700 |
|---|-----------------|----------------|----------------------|----------|----------|----------|----------|--|---------------------------|-----------------------------|
| • | 2,0 | 3,0 | 0,5 | 1,9 | 50,0 | 12,0 | 6,0 | 2 | KF700020DIA1 | 47,00 |
| • | 2,0 | 3,0 | 0,5 | 1,9 | 100,0 | 20,0 | 10,0 | 2 | KF700020DIA2 | 50,00 |
| • | 3,0 | 3,0 | 0,5 | 2,9 | 60,0 | 16,0 | 8,0 | 2 | KF700030DIA1 | 48,00 |
| • | 3,0 | 3,0 | 0,5 | 2,9 | 100,0 | 24,0 | 12,0 | 2 | KF700030DIA2 | 50,00 |
| • | 4,0 | 4,0 | 0,5 | 3,8 | 60,0 | 20,0 | 10,0 | 2 | KF700040DIA1 | 61,80 |
| • | 4,0 | 4,0 | 0,5 | 3,8 | 100,0 | 30,0 | 15,0 | 2 | KF700040DIA2 | 64,20 |
| • | 5,0 | 5,0 | 0,5 | 4,8 | 60,0 | 24,0 | 12,0 | 2 | KF700050DIA1 | 75,80 |
| • | 5,0 | 5,0 | 0,5 | 4,8 | 100,0 | 30,0 | 15,0 | 2 | KF700050DIA2 | 80,80 |
| • | 6,0 | 6,0 | 0,5 | 5,8 | 75,0 | 40,0 | 20,0 | 2 | KF700060DIA1 | 84,00 |
| • | 6,0 | 6,0 | 0,5 | 5,8 | 100,0 | 50,0 | 25,0 | 2 | KF700060DIA2 | 90,00 |
| • | 6,0 | 6,0 | 0,5 | 5,8 | 150,0 | 60,0 | 30,0 | 2 | KF700060DIA3 | 99,00 |
| • | 8,0 | 8,0 | 1,0 | 7,8 | 75,0 | 40,0 | 20,0 | 2 | KF700080DIA1 | 111,00 |
| • | 8,0 | 8,0 | 1,0 | 7,8 | 100,0 | 50,0 | 25,0 | 2 | KF700080DIA2 | 119,40 |
| • | 8,0 | 8,0 | 1,0 | 7,8 | 150,0 | 60,0 | 30,0 | 2 | KF700080DIA3 | 133,00 |
| • | 10,0 | 10,0 | 1,0 | 9,8 | 100,0 | 50,0 | 25,0 | 2 | KF700100DIA1 | 154,00 |
| • | 10,0 | 10,0 | 1,0 | 9,8 | 150,0 | 60,0 | 30,0 | 2 | KF700100DIA2 | 169,00 |
| • | 12,0 | 12,0 | 1,0 | 11,8 | 100,0 | 50,0 | 25,0 | 2 | KF700120DIA1 | 181,60 |
| • | 12,0 | 12,0 | 1,0 | 11,8 | 150,0 | 80,0 | 40,0 | 2 | KF700120DIA2 | 211,60 |
| • | 16,0 | 16,0 | 1,5 | 15,8 | 100,0 | 50,0 | 25,0 | 2 | KF700160DIA1 | 277,20 |
| • | 16,0 | 16,0 | 1,5 | 15,8 | 150,0 | 80,0 | 40,0 | 2 | KF700160DIA2 | 310,00 |

VHM-RADIUSFRÄSER

KFB700 - DIAMANT



Einsatzgebiete: Mit Diamant-Beschichtung zur Bearbeitung von stark abrasiven Werkstoffen. Insbesondere für Graphit, AlSi-Legierungen (Si>10%) und faserverstärkten Werkstoffen. Ausführung mit abgesetztem Halseinschliff (d3) sowie Eckenradius.

application: Diamond-coated to machine very abrasive materials. Especially suited for graphite, AlSi-alloys (Si>10%) and fiber-reinforced materials. With reduced shank (d3) and edge radius.



Diamant-beschichtete Vollhartmetallfräser sind auch in anderen Längen und Durchmessern erhältlich.
Diamond-coated solid carbide end mills are available with other lengths and diameters upon request.

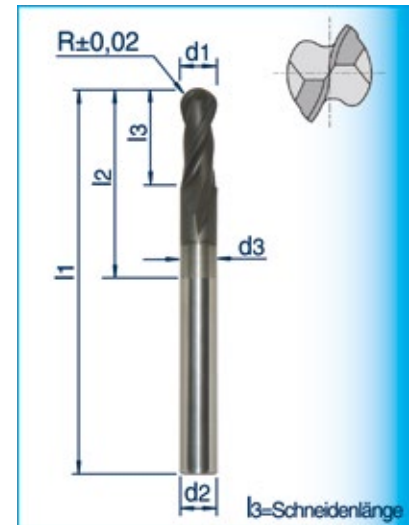

- ab Lager / ex stock
- kurzfristig / on short notice
- Lieferzeit ca. 1-2 Wochen / delivery time approx. 1-2 weeks

| | d1 | d2 | d3 | l1 | l2 | l3 | Zähnezahl (no. of cutting edges) | Artikel-Nr. (code no.) | Preis Euro / je KFB700 |
|---|-----------|----------|------|-------|------|------|--|---------------------------|------------------------------|
| | h10 mm | h6 mm | mm | mm | mm | mm | | | |
| • | 2,0 | 3,0 | 1,9 | 50,0 | 12,0 | 6,0 | 2 | KFB700020DI1 | 47,00 |
| • | 2,0 | 3,0 | 1,9 | 100,0 | 20,0 | 10,0 | 2 | KFB700020DI2 | 50,00 |
| • | 3,0 | 3,0 | 2,9 | 60,0 | 16,0 | 8,0 | 2 | KFB700030DI1 | 48,00 |
| • | 3,0 | 3,0 | 2,9 | 100,0 | 24,0 | 12,0 | 2 | KFB700030DI2 | 50,00 |
| • | 4,0 | 4,0 | 3,8 | 60,0 | 20,0 | 10,0 | 2 | KFB700040DI1 | 61,80 |
| • | 4,0 | 4,0 | 3,8 | 100,0 | 30,0 | 15,0 | 2 | KFB700040DI2 | 64,20 |
| • | 5,0 | 5,0 | 4,8 | 60,0 | 24,0 | 12,0 | 2 | KFB700050DI1 | 75,80 |
| • | 5,0 | 5,0 | 4,8 | 100,0 | 30,0 | 15,0 | 2 | KFB700050DI2 | 80,80 |
| • | 6,0 | 6,0 | 5,8 | 75,0 | 40,0 | 20,0 | 2 | KFB700060DI1 | 84,00 |
| • | 6,0 | 6,0 | 5,8 | 100,0 | 50,0 | 25,0 | 2 | KFB700060DI2 | 90,00 |
| • | 6,0 | 6,0 | 5,8 | 150,0 | 60,0 | 30,0 | 2 | KFB700060DI3 | 99,00 |
| • | 8,0 | 8,0 | 7,8 | 75,0 | 40,0 | 20,0 | 2 | KFB700080DI1 | 111,00 |
| • | 8,0 | 8,0 | 7,8 | 100,0 | 50,0 | 25,0 | 2 | KFB700080DI2 | 119,40 |
| • | 8,0 | 8,0 | 7,8 | 150,0 | 60,0 | 30,0 | 2 | KFB700080DI3 | 133,00 |
| • | 10,0 | 10,0 | 9,8 | 100,0 | 50,0 | 25,0 | 2 | KFB700100DI1 | 154,00 |
| • | 10,0 | 10,0 | 9,8 | 150,0 | 60,0 | 30,0 | 2 | KFB700100DI2 | 169,00 |
| • | 12,0 | 12,0 | 11,8 | 100,0 | 50,0 | 25,0 | 2 | KFB700120DI1 | 181,60 |
| • | 12,0 | 12,0 | 11,8 | 150,0 | 80,0 | 40,0 | 2 | KFB700120DI2 | 211,60 |
| • | 16,0 | 16,0 | 15,8 | 100,0 | 50,0 | 25,0 | 2 | KFB700160DI1 | 277,20 |
| • | 16,0 | 16,0 | 15,8 | 150,0 | 80,0 | 40,0 | 2 | KFB700160DI2 | 310,00 |

VHM-SCHRUPPFRÄSER

KF310 / KF311 / KFB311 - ZX3



Einsatzgebiete: Höchste Zerspanleistung durch Feinkornprofil in Verbindung mit verstärktem Kern, Substrat K50F und ZX3-Beschichtung. Für Stahlwerkstoffe, gehärtete Stähle und Gußwerkstoffe.

application: Highest cutting performance due to the fine-knurled profile in connection with the reinforced web, substrate K50F and ZX3-coating. For steel materials, hardened steel and cast materials.

KF310 = 3-5 Schneiden, kurze Ausführung, Zylinderschaft DIN6535-HB (Weldon-Spannfläche)
 KF311 = 3-5 Schneiden, lange Ausführung, Zylinderschaft DIN6535-HB (Weldon-Spannfläche)
 KFB311 = 3-4 Schneiden, lange Ausführung, Zylinderschaft DIN6535-HA



- ab Lager / ex stock
- kurzfristig / on short notice
- Lieferzeit auf Anfrage / delivery time upon request

VHM-Schrupfräser KF310 - kurze Ausführung - Weldon-Spannfläche

| d1 h10 mm | d2 h6 mm | l2 mm | l1 mm | Zähnezahl (no. of cutting edges) | Artikel-Nr. (code no.) | Preis Euro / je KF310 - ZX3 |
|-----------------|----------------|----------|----------|--|---------------------------|-----------------------------------|
| • 6,0 | 6,0 | 7,0 | 54,0 | 3 | KF310060ZX3 | 24,20 |
| • 7,0 | 8,0 | 8,0 | 58,0 | 3 | KF310070ZX3 | 28,20 |
| • 8,0 | 8,0 | 9,0 | 58,0 | 3 | KF310080ZX3 | 28,20 |
| • 9,0 | 10,0 | 13,0 | 66,0 | 4 | KF310090ZX3 | 42,40 |
| • 10,0 | 10,0 | 14,0 | 66,0 | 4 | KF310100ZX3 | 42,40 |
| • 12,0 | 12,0 | 16,0 | 73,0 | 4 | KF310120ZX3 | 54,00 |
| • 14,0 | 14,0 | 18,0 | 75,0 | 4 | KF310140ZX3 | 65,80 |
| • 16,0 | 16,0 | 22,0 | 82,0 | 4 | KF310160ZX3 | 88,20 |
| • 18,0 | 18,0 | 24,0 | 84,0 | 4 | KF310180ZX3 | 113,20 |
| • 20,0 | 20,0 | 26,0 | 92,0 | 4 | KF310200ZX3 | 142,00 |
| • 25,0 | 25,0 | 25,0 | 110,0 | 5 | KF310250ZX3 | 249,20 |

VHM-Schrupfräser KF311 - lange Ausführung - Weldon-Spannfläche

| d1 h10 mm | d2 h6 mm | l2 mm | l1 mm | Zähnezahl (no. of cutting edges) | Artikel-Nr. (code no.) | Preis Euro / je KF311 - ZX3 |
|-----------------|----------------|----------|----------|--|---------------------------|-----------------------------------|
| • 6,0 | 6,0 | 16,0 | 57,0 | 3 | KF311060ZX3 | 26,40 |
| • 7,0 | 8,0 | 16,0 | 63,0 | 3 | KF311070ZX3 | 30,40 |
| • 8,0 | 8,0 | 16,0 | 63,0 | 3 | KF311080ZX3 | 30,40 |
| • 9,0 | 10,0 | 19,0 | 72,0 | 4 | KF311090ZX3 | 45,40 |
| • 10,0 | 10,0 | 22,0 | 72,0 | 4 | KF311100ZX3 | 45,40 |
| • 12,0 | 12,0 | 26,0 | 83,0 | 4 | KF311120ZX3 | 58,20 |
| • 14,0 | 14,0 | 26,0 | 83,0 | 4 | KF311140ZX3 | 70,80 |
| • 16,0 | 16,0 | 32,0 | 92,0 | 4 | KF311160ZX3 | 94,80 |
| • 18,0 | 18,0 | 32,0 | 92,0 | 4 | KF311180ZX3 | 122,00 |
| • 20,0 | 20,0 | 38,0 | 104,0 | 4 | KF311200ZX3 | 152,80 |
| • 25,0 | 25,0 | 45,0 | 121,0 | 5 | KF311250ZX3 | 267,60 |

VHM-Radius-Schrupfräser KFB311 - lange Ausführung

| d1 h10 mm | d2 h6 mm | Radius R $\pm 0,02$ | l2 mm | l1 mm | Zähnezahl (no. of cutting edges) | Artikel-Nr. (code no.) | Preis Euro / je KFB311 - ZX3 |
|-----------------|----------------|---------------------------|----------|----------|--|---------------------------|------------------------------------|
| • 6,0 | 6,0 | 3,0 | 16,0 | 57,0 | 3 | KFB311060ZX3 | 40,20 |
| • 8,0 | 8,0 | 4,0 | 16,0 | 63,0 | 3 | KFB311080ZX3 | 46,80 |
| • 10,0 | 10,0 | 5,0 | 22,0 | 72,0 | 4 | KFB311100ZX3 | 69,80 |
| • 12,0 | 12,0 | 6,0 | 26,0 | 83,0 | 4 | KFB311120ZX3 | 89,60 |
| • 14,0 | 14,0 | 7,0 | 26,0 | 83,0 | 4 | KFB311140ZX3 | 108,40 |
| • 16,0 | 16,0 | 8,0 | 32,0 | 92,0 | 4 | KFB311160ZX3 | 145,60 |
| • 18,0 | 18,0 | 9,0 | 32,0 | 92,0 | 4 | KFB311180ZX3 | 186,60 |
| • 20,0 | 20,0 | 10,0 | 38,0 | 104,0 | 4 | KFB311200ZX3 | 234,60 |

VHM-SCHRUPP-SCHLICHTFRÄSER

KF306 - ZX5



Einsatzgebiete: Zum Schrubb- und Schlichtfräsen mit extrem hohen Vorschüben in Stahl und NE-Metallen. Das spezielle Trapezprofil bietet im Einsatz hohe Zerspanungsleistung, doppelte Standzeit und sehr gute Oberflächengüten.

application: For roughing and finishing operations with extremely high feeds in steel and nonferrous metals. The special trapezoidal profile ensures high cutting performance, duplication of tool life and very good surface qualities.

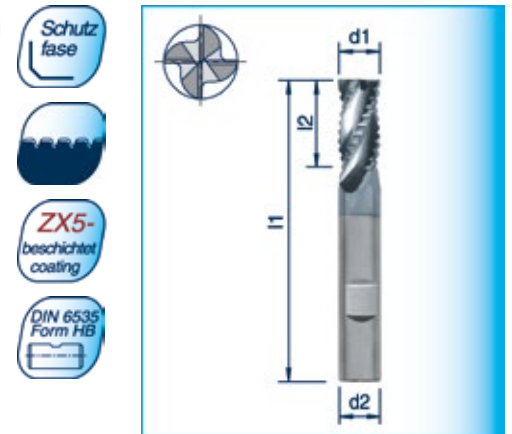

- ab Lager / ex stock
- kurzfristig / on short notice
- Lieferzeit auf Anfrage / delivery time upon request

| d1 h10 mm | d2 h6 mm | l2 mm | l1 mm | Zähnezahl (no. of cutting edges) | Artikel-Nr. (code no.) | Preis Euro / je KF306 - ZX5 |
|-----------------|----------------|----------|----------|--|---------------------------|-----------------------------------|
| • 6,0 | 6,0 | 13,0 | 57,0 | 3 | KF306060TIC | 39,40 |
| • 8,0 | 8,0 | 19,0 | 63,0 | 3 | KF306080TIC | 48,80 |
| • 10,0 | 10,0 | 22,0 | 72,0 | 4 | KF306100TIC | 53,40 |
| • 12,0 | 12,0 | 26,0 | 83,0 | 4 | KF306120TIC | 67,20 |
| • 14,0 | 14,0 | 26,0 | 83,0 | 4 | KF306140TIC | 86,20 |
| • 16,0 | 16,0 | 32,0 | 92,0 | 4 | KF306160TIC | 101,20 |
| • 18,0 | 18,0 | 32,0 | 96,0 | 4 | KF306180TIC | 138,00 |
| • 20,0 | 20,0 | 38,0 | 104,0 | 4 | KF306200TIC | 152,80 |

VHM-SCHRUPPFRÄSER MIT INNENKÜHLUNG

KF319 - ZX4



Einsatzgebiete: Für Stahlwerkstoffe, rost- und säurebeständige Stähle sowie für Gußwerkstoffe.

application: For steel materials, rust- and acid-resistant steels as well as for casting materials.

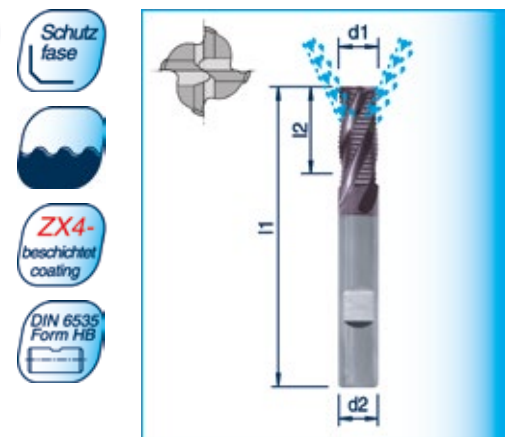

- ab Lager / ex stock
- kurzfristig / on short notice
- Lieferzeit auf Anfrage / delivery time upon request

| d1 h10 mm | d2 h6 mm | l2 mm | l1 mm | Zähnezahl (no. of cutting edges) | Artikel-Nr. (code no.) | Preis Euro / je KF319 - ZX4 |
|-----------------|----------------|----------|----------|--|---------------------------|-----------------------------------|
| • 6,0 | 6,0 | 13,0 | 57,0 | 4 | KF319060ZX4 | 45,40 |
| • 8,0 | 8,0 | 19,0 | 63,0 | 4 | KF319080ZX4 | 50,40 |
| • 10,0 | 10,0 | 22,0 | 72,0 | 4 | KF319100ZX4 | 55,20 |
| • 12,0 | 12,0 | 26,0 | 83,0 | 4 | KF319120ZX4 | 74,60 |
| • 16,0 | 16,0 | 32,0 | 92,0 | 4 | KF319160ZX4 | 104,20 |
| • 20,0 | 20,0 | 38,0 | 104,0 | 4 | KF319200ZX4 | 154,20 |

VHM-UNIVERSAL-TOOL 90°

KF620 - ZX3



Einsatzgebiete: Das Universal-Tool ist konzipiert zum Fräsen, Bohren und Senken mit nur einem Werkzeug. Bis zu 8 Bearbeitungsvorgänge ohne Werkzeugwechsel sind möglich. Werkzeugrüstzeiten und Werkzeugbevorratung werden eingespart.

application: This universal tool is constructed to mill, bore and countersink all in one. Up to 8 machining operations are possible without changing the tool. You save set-up time and stockkeeping.

Hinweis/Einsatzempfehlung:

unbeschichtet K15F



ZX3-(TiAlN)-beschichtet

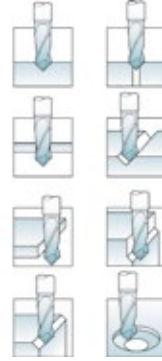

- ab Lager / ex stock
- kurzfristig / on short notice
- Lieferzeit auf Anfrage / delivery time upon request

| d1 0/-0,01 mm | d2 h6 mm | z | l1 mm | l2 mm | Spitze □ ° | T mm | Artikel-Nr. (code no.) unbeschichtet | Preis Euro / je unbeschichtet | Artikel-Nr. (code no.) ZX3 | Preis Euro / je ZX3 |
|---------------------|----------------|---|----------|----------|------------------|---------|--|-------------------------------------|----------------------------------|---------------------------|
| 0,50 | 3,0 | 2 | 39 | 1,0 | 90° | 0,05 | KF620005 | 18,80 | KF620005ZX3 | 21,40 |
| 0,60 | 3,0 | 2 | 39 | 1,2 | 90° | 0,06 | KF620006 | 18,80 | KF620006ZX3 | 21,40 |
| 0,70 | 3,0 | 2 | 39 | 1,4 | 90° | 0,07 | KF620007 | 18,80 | KF620007ZX3 | 21,40 |
| 0,80 | 3,0 | 2 | 39 | 1,6 | 90° | 0,08 | KF620008 | 18,80 | KF620008ZX3 | 21,40 |
| 0,90 | 3,0 | 2 | 39 | 1,8 | 90° | 0,09 | KF620009 | 18,80 | KF620009ZX3 | 21,40 |
| 1,00 | 3,0 | 2 | 39 | 2,0 | 90° | 0,10 | KF620010 | 18,80 | KF620010ZX3 | 21,40 |
| 1,20 | 3,0 | 2 | 39 | 2,4 | 90° | 0,12 | KF620012 | 18,80 | KF620012ZX3 | 21,40 |
| 1,40 | 3,0 | 2 | 39 | 2,8 | 90° | 0,14 | KF620014 | 18,80 | KF620014ZX3 | 21,40 |
| 1,50 | 3,0 | 2 | 39 | 3,0 | 90° | 0,15 | KF620015 | 18,80 | KF620015ZX3 | 21,40 |
| 1,80 | 3,0 | 2 | 39 | 3,6 | 90° | 0,18 | KF620018 | 18,80 | KF620018ZX3 | 21,40 |
| 2,00 | 3,0 | 2 | 39 | 4,0 | 90° | 0,20 | KF620020 | 18,80 | KF620020ZX3 | 21,40 |
| 2,50 | 3,0 | 2 | 39 | 5,0 | 90° | 0,25 | KF620025 | 18,80 | KF620025ZX3 | 21,40 |
| 3,00 | 4,0 | 2 | 50 | 6,0 | 90° | 0,30 | KF620030 | 24,80 | KF620030ZX3 | 26,80 |
| 4,00 | 5,0 | 2 | 50 | 8,0 | 90° | 0,40 | KF620040 | 25,80 | KF620040ZX3 | 30,20 |
| 5,00 | 6,0 | 2 | 50 | 10,0 | 90° | 0,50 | KF620050 | 27,20 | KF620050ZX3 | 29,40 |
| 6,00 | 8,0 | 2 | 60 | 12,0 | 90° | 0,60 | KF620060 | 33,40 | KF620060ZX3 | 35,80 |
| 8,00 | 10,0 | 2 | 70 | 16,0 | 90° | 0,80 | KF620080 | 46,40 | KF620080ZX3 | 49,80 |
| 10,00 | 12,0 | 2 | 70 | 18,0 | 90° | 1,00 | KF620100 | 59,60 | KF620100ZX3 | 63,80 |
| 12,00 | 12,0 | 2 | 70 | 20,0 | 90° | 1,20 | KF620120 | 57,80 | KF620120ZX3 | 62,80 |
| 16,00 | 16,0 | 2 | 80 | 26,0 | 90° | 1,60 | KF620160 | 83,40 | KF620160ZX3 | 90,80 |
| 20,00 | 20,0 | 2 | 100 | 32,0 | 90° | 2,00 | KF620200 | 144,40 | KF620200ZX3 | 155,20 |

Anwendungsmöglichkeiten:

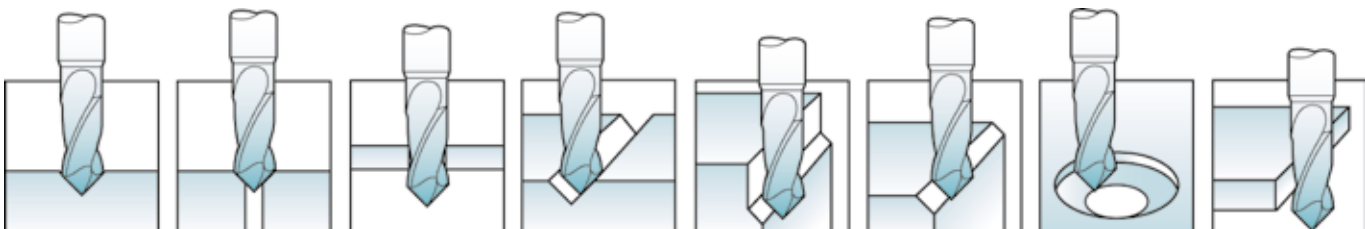

VHM-UNIVERSAL-TOOL

KF621 (60°) / KF622 (120°) - ZX3



Einsatzgebiete: Das Universal-Tool ist konzipiert zum Fräsen, Bohren und Senken mit nur einem Werkzeug. Bis zu 8 Bearbeitungsvorgänge ohne Werkzeugwechsel sind möglich. Werkzeugrüstzeiten und Werkzeugbevorzugung werden eingespart.

application: This universal tool is constructed to mill, bore and countersink all in one. Up to 8 machining operations are possible without changing the tool. You save set-up time and stockkeeping.

Hinweis/Einsatzempfehlung:

unbeschichtet K15F



ZX3-(TiAlN)-beschichtet

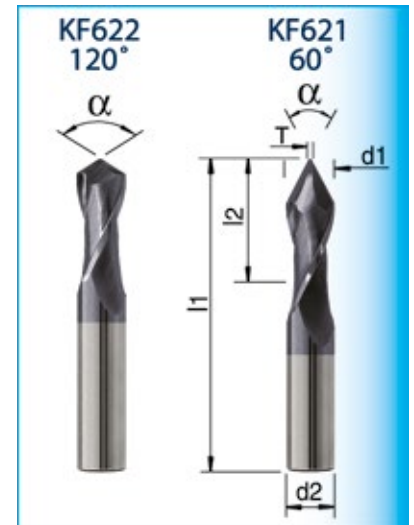
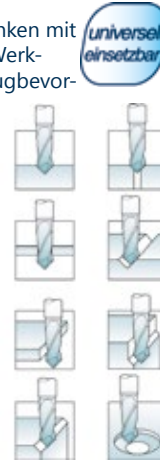

- ab Lager / ex stock
- kurzfristig / on short notice
- Lieferzeit auf Anfrage / delivery time upon request

VHM-Universal-Tool 60°

| d1 0/-0,01 mm | d2 h6 mm | z | l1 mm | l2 mm | Spitze □ ° | T mm | Artikel-Nr. (code no.) unbeschichtet | Preis Euro / je unbeschichtet | Artikel-Nr. (code no.) ZX3 | Preis Euro / je ZX3 |
|---------------------|----------------|---|----------|----------|------------------|---------|--|-------------------------------------|----------------------------------|---------------------------|
| 0,50 | 3,0 | 2 | 39 | 2,0 | 60° | 0,05 | KF621005 | • 38,60 | KF621005ZX3 | --- |
| 1,00 | 3,0 | 2 | 39 | 2,0 | 60° | 0,10 | KF621010 | • 23,40 | KF621010ZX3 | • 26,00 |
| 1,50 | 3,0 | 2 | 39 | 3,0 | 60° | 0,15 | KF621015 | • 23,40 | KF621015ZX3 | • 26,00 |
| 2,00 | 3,0 | 2 | 39 | 4,0 | 60° | 0,20 | KF621020 | • 23,40 | KF621020ZX3 | • 26,00 |
| 2,50 | 3,0 | 2 | 39 | 5,0 | 60° | 0,25 | KF621025 | • 23,40 | KF621025ZX3 | • 26,00 |
| 3,00 | 4,0 | 2 | 50 | 6,0 | 60° | 0,30 | KF621030 | • 30,60 | KF621030ZX3 | • 33,00 |
| 4,00 | 5,0 | 2 | 50 | 8,0 | 60° | 0,40 | KF621040 | • 32,00 | KF621040ZX3 | • 34,40 |
| 5,00 | 6,0 | 2 | 50 | 10,0 | 60° | 0,50 | KF621050 | • 34,20 | KF621050ZX3 | • 36,00 |
| 6,00 | 8,0 | 2 | 60 | 12,0 | 60° | 0,60 | KF621060 | • 41,80 | KF621060ZX3 | • 44,00 |
| 8,00 | 10,0 | 2 | 70 | 16,0 | 60° | 0,80 | KF621080 | • 57,80 | KF621080ZX3 | • 61,60 |
| 10,00 | 12,0 | 2 | 70 | 18,0 | 60° | 1,00 | KF621100 | • 74,40 | KF621100ZX3 | • 78,80 |
| 12,00 | 12,0 | 2 | 70 | 20,0 | 60° | 1,20 | KF621120 | • 72,40 | KF621120ZX3 | • 77,40 |
| 16,00 | 16,0 | 2 | 80 | 26,0 | 60° | 1,60 | KF621160 | • 104,60 | KF621160ZX3 | • 112,40 |
| 20,00 | 20,0 | 2 | 100 | 32,0 | 60° | 2,00 | KF621200 | • 180,40 | KF621200ZX3 | • 191,60 |

VHM-Universal-Tool 120°

| d1 0/-0,01 mm | d2 h6 mm | z | l1 mm | l2 mm | Spitze □ ° | T mm | Artikel-Nr. (code no.) unbeschichtet | Preis Euro / je unbeschichtet | Artikel-Nr. (code no.) ZX3 | Preis Euro / je ZX3 |
|---------------------|----------------|---|----------|----------|------------------|---------|--|-------------------------------------|----------------------------------|---------------------------|
| 1,00 | 3,0 | 2 | 39 | 2,0 | 120° | 0,10 | KF622010 | • 18,80 | KF622010ZX3 | • 21,40 |
| 1,50 | 3,0 | 2 | 39 | 3,0 | 120° | 0,15 | KF622015 | • 18,80 | KF622015ZX3 | • 21,40 |
| 2,00 | 3,0 | 2 | 39 | 4,0 | 120° | 0,20 | KF622020 | • 18,80 | KF622020ZX3 | • 21,40 |
| 2,50 | 3,0 | 2 | 39 | 5,0 | 120° | 0,25 | KF622025 | • 18,80 | KF622025ZX3 | • 21,40 |
| 3,00 | 4,0 | 2 | 50 | 6,0 | 120° | 0,30 | KF622030 | • 24,80 | KF622030ZX3 | • 26,80 |
| 4,00 | 5,0 | 2 | 50 | 8,0 | 120° | 0,40 | KF622040 | • 25,80 | KF622040ZX3 | • 28,00 |
| 5,00 | 6,0 | 2 | 50 | 10,0 | 120° | 0,50 | KF622050 | • 27,20 | KF622050ZX3 | • 29,40 |
| 6,00 | 8,0 | 2 | 60 | 12,0 | 120° | 0,60 | KF622060 | • 33,20 | KF622060ZX3 | • 35,80 |
| 8,00 | 10,0 | 2 | 70 | 16,0 | 120° | 0,80 | KF622080 | • 46,40 | KF622080ZX3 | • 49,80 |
| 10,00 | 12,0 | 2 | 70 | 18,0 | 120° | 1,00 | KF622100 | • 59,60 | KF622100ZX3 | • 63,80 |
| 12,00 | 12,0 | 2 | 70 | 20,0 | 120° | 1,20 | KF622120 | • 57,80 | KF622120ZX3 | • 62,80 |
| 16,00 | 16,0 | 2 | 80 | 26,0 | 120° | 1,60 | KF622160 | • 83,40 | KF622160ZX3 | • 90,80 |
| 20,00 | 20,0 | 2 | 100 | 32,0 | 120° | 2,00 | KF622200 | • 144,40 | KF622200ZX3 | • 155,20 |

VHM-MICRO-SCHAFTFRÄSER

KF350 (1,5xØ)



Einsatzgebiete: Universell einsetzbar, sowohl für den Dentalbereich, Kleinstformenbau, Uhren- und Schmuckindustrie sowie zum Fräsen von Elektroden. Extrakurze, stabile Ausführung.

application: Universal applications. Well suited for dental, jewelry and miniature mould making industry as well as for the machining of electrodes. Extreme short, stable construction.

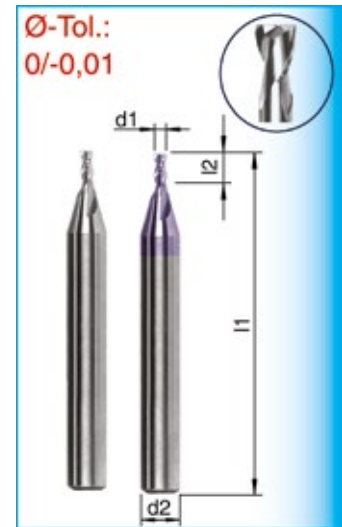

Hinweis/Einsatzempfehlung:

unbeschichtet K15F



ZX3-(TiAlN)-beschichtet



Diamant-beschichtet



- ab Lager / ex stock
- kurzfristig / on short notice
- Lieferzeit ca. 1-2 Wochen / delivery time approx. 1-2 weeks

| d1 0/-0,01 | d2 h6 | z | l1 | l2 | Artikel-Nr. unbeschichtet (uncoated) | Preis Euro / je unbeschichtet (uncoated) | Artikel-Nr. (code no.) ZX3 | Preis Euro / je ZX3 | Artikel-Nr. (code no.) Diamant | Preis Euro / je Diamant |
|---------------|----------|---|----|------|--|--|----------------------------------|---------------------------|--------------------------------------|-------------------------------|
| 0,10 | 3 | 2 | 39 | 0,10 | KF3500010 | 44,80 | | --- | | --- |
| 0,15 | 3 | 2 | 39 | 0,20 | KF3500015 | 37,60 | | --- | | --- |
| 0,20 | 3 | 2 | 39 | 0,30 | KF3500020 | 32,00 | | --- | | --- |
| 0,25 | 3 | 2 | 39 | 0,35 | KF3500025 | 32,00 | | --- | | --- |
| 0,30 | 3 | 2 | 39 | 0,45 | KF3500030 | 19,00 | KF3500030ZX3 | 21,60 | KF3500030DIA | 48,80 |
| 0,40 | 3 | 2 | 39 | 0,60 | KF3500040 | 15,20 | KF3500040ZX3 | 18,00 | KF3500040DIA | 45,00 |
| 0,50 | 3 | 2 | 39 | 0,75 | KF3500050 | 13,20 | KF3500050ZX3 | 16,20 | KF3500050DIA | 43,00 |
| 0,60 | 3 | 2 | 39 | 0,90 | KF3500060 | 13,20 | KF3500060ZX3 | 16,20 | KF3500060DIA | 43,00 |
| 0,70 | 3 | 2 | 39 | 1,05 | KF3500070 | 13,20 | KF3500070ZX3 | 16,20 | KF3500070DIA | 43,00 |
| 0,80 | 3 | 2 | 39 | 1,20 | KF3500080 | 13,20 | KF3500080ZX3 | 16,20 | KF3500080DIA | 43,00 |
| 0,90 | 3 | 2 | 39 | 1,35 | KF3500090 | 13,20 | KF3500090ZX3 | 16,20 | KF3500090DIA | 43,00 |
| 1,00 | 3 | 2 | 39 | 1,50 | KF3500100 | 13,20 | KF3500100ZX3 | 16,20 | KF3500100DIA | 43,00 |
| 1,10 | 3 | 2 | 39 | 1,65 | KF3500110 | 13,20 | KF3500110ZX3 | 16,20 | KF3500110DIA | 43,00 |
| 1,20 | 3 | 2 | 39 | 1,80 | KF3500120 | 13,20 | KF3500120ZX3 | 16,20 | | --- |
| 1,30 | 3 | 2 | 39 | 1,95 | KF3500130 | 14,40 | KF3500130ZX3 | 17,40 | | --- |
| 1,40 | 3 | 2 | 39 | 2,10 | KF3500140 | 14,40 | KF3500140ZX3 | 17,40 | | --- |
| 1,50 | 3 | 2 | 39 | 2,25 | KF3500150 | 14,40 | KF3500150ZX3 | 17,40 | KF3500150DIA | 44,20 |
| 1,60 | 3 | 2 | 39 | 2,40 | KF3500160 | 15,20 | KF3500160ZX3 | 18,00 | KF3500160DIA | 54,80 |
| 1,70 | 3 | 2 | 39 | 2,55 | KF3500170 | 15,20 | KF3500170ZX3 | 18,00 | | --- |
| 1,80 | 3 | 2 | 39 | 2,70 | KF3500180 | 15,20 | KF3500180ZX3 | 18,00 | KF3500180DIA | 54,80 |
| 1,90 | 3 | 2 | 39 | 2,85 | KF3500190 | 15,20 | KF3500190ZX3 | 18,00 | | --- |
| 2,00 | 3 | 2 | 39 | 3,00 | KF3500200 | 14,40 | KF3500200ZX3 | 17,40 | KF3500200DIA | 54,00 |

VHM-MICRO-SCHAFTFRÄSER

KF351 (2-3xØ)



Einsatzgebiete: Universell einsetzbar, sowohl für den Dentalbereich, Kleinstformenbau, Uhren- und Schmuckindustrie sowie zum Fräsen von Elektroden. Eingriffstiefe bis 3 x Ø.

application: Universal applications. Well suited for dental, jewelry and miniature mould making industry as well as for the machining of electrodes. Working depth up to 3 x dia.

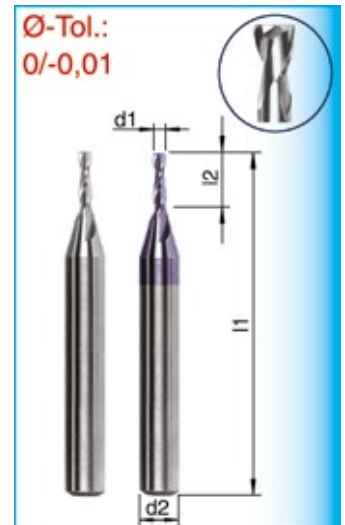

Hinweis/Einsatzempfehlung:

| | | | | | | | | |
|--------------------|-----------------------|------------------|-------------------------|-------------------------|-------------------------------|---------------------|----------------|------------|
| unbeschichtet K15F | | | ZX3-(TiAlN)-beschichtet | | | Diamant-beschichtet | | |
| STAHL steeel | Kunststoff plastic | ALU aluminium | STAHL steeel | INOX stainless steel | Titan Inconel Hastelloy | Graphit graphite | ALU > 9% Si | GFK CFK |
| GUSS cast iron | NE non ferrous | Messing brass | HRC 56 | | | | | |

- ab Lager / ex stock
- kurzfristig / on short notice
- Lieferzeit ca. 1-2 Wochen / delivery time approx. 1-2 weeks

| d1 0/-0,01 | d2 h6 | z | l1 | l2 | Artikel-Nr. unbeschichtet (uncoated) | Preis Euro / je unbeschichtet (uncoated) | Artikel-Nr. (code no.) ZX3 | Preis Euro / je ZX3 | Artikel-Nr. (code no.) Diamant | Preis Euro / je Diamant |
|---------------|----------|---|----|------|--|--|----------------------------------|---------------------------|--------------------------------------|-------------------------------|
| 0,10 | 3,0 | 2 | 39 | 0,2 | KF3510010 | 44,80 | | --- | | --- |
| 0,15 | 3,0 | 2 | 39 | 0,3 | KF3510015 | 37,60 | | --- | | --- |
| 0,20 | 3,0 | 2 | 39 | 0,5 | KF3510020 | 32,00 | | --- | | --- |
| 0,25 | 3,0 | 2 | 39 | 0,5 | KF3510025 | 32,00 | | --- | | --- |
| 0,30 | 3,0 | 2 | 39 | 1,0 | KF3510030 | 19,00 | KF3510030ZX3 | 21,60 | KF3510030DIA | 48,80 |
| 0,35 | 3,0 | 2 | 39 | 1,0 | KF3510035 | 19,00 | KF3510035ZX3 | 21,60 | | --- |
| 0,40 | 3,0 | 2 | 39 | 1,0 | KF3510040 | 15,20 | KF3510040ZX3 | 18,00 | KF3510040DIA | 45,00 |
| 0,45 | 3,0 | 2 | 39 | 1,0 | KF3510045 | 22,40 | KF3510045ZX3 | 25,00 | | --- |
| 0,50 | 3,0 | 2 | 39 | 1,5 | KF3510050 | 13,20 | KF3510050ZX3 | 16,20 | KF3510050DIA | 43,00 |
| 0,55 | 3,0 | 2 | 39 | 1,5 | KF3510055 | 17,40 | KF3510055ZX3 | 20,20 | | --- |
| 0,60 | 3,0 | 2 | 39 | 1,5 | KF3510060 | 13,20 | KF3510060ZX3 | 16,20 | KF3510060DIA | 43,00 |
| 0,65 | 3,0 | 2 | 39 | 1,5 | KF3510065 | 17,40 | KF3510065ZX3 | 20,20 | | --- |
| 0,70 | 3,0 | 2 | 39 | 2,0 | KF3510070 | 13,20 | KF3510070ZX3 | 16,20 | KF3510070DIA | 43,00 |
| 0,75 | 3,0 | 2 | 39 | 2,0 | KF3510075 | 17,40 | KF3510075ZX3 | 20,20 | | --- |
| 0,80 | 3,0 | 2 | 39 | 2,0 | KF3510080 | 13,20 | KF3510080ZX3 | 16,20 | KF3510080DIA | 43,00 |
| 0,85 | 3,0 | 2 | 39 | 2,0 | KF3510085 | 17,40 | KF3510085ZX3 | 20,20 | | --- |
| 0,90 | 3,0 | 2 | 39 | 2,5 | KF3510090 | 13,20 | KF3510090ZX3 | 16,20 | KF3510090DIA | 43,00 |
| 0,95 | 3,0 | 2 | 39 | 2,5 | KF3510095 | 17,40 | KF3510095ZX3 | 20,20 | | --- |
| 1,00 | 3,0 | 2 | 39 | 3,0 | KF3510100 | 13,20 | KF3510100ZX3 | 16,20 | KF3510100DIA | 43,00 |
| 1,05 | 3,0 | 2 | 39 | 3,0 | KF3510105 | 17,40 | KF3510105ZX3 | 20,20 | | --- |
| 1,10 | 3,0 | 2 | 39 | 3,0 | KF3510110 | 13,20 | KF3510110ZX3 | 16,20 | | --- |
| 1,15 | 3,0 | 2 | 39 | 3,0 | KF3510115 | 17,40 | KF3510115ZX3 | 20,20 | | --- |
| 1,20 | 3,0 | 2 | 39 | 4,0 | KF3510120 | 13,20 | KF3510120ZX3 | 16,20 | KF3510120DIA | 43,00 |
| 1,25 | 3,0 | 2 | 39 | 4,0 | KF3510125 | 17,40 | KF3510125ZX3 | 20,20 | | --- |
| 1,30 | 3,0 | 2 | 39 | 4,0 | KF3510130 | 14,40 | KF3510130ZX3 | 17,40 | | --- |
| 1,40 | 3,0 | 2 | 39 | 4,0 | KF3510140 | 14,40 | KF3510140ZX3 | 17,40 | KF3510140DIA | 44,20 |
| 1,50 | 3,0 | 2 | 39 | 4,0 | KF3510150 | 14,40 | KF3510150ZX3 | 17,40 | KF3510150DIA | 44,20 |
| 1,60 | 3,0 | 2 | 39 | 5,0 | KF3510160 | 15,20 | KF3510160ZX3 | 18,00 | KF3510160DIA | 54,80 |
| 1,70 | 3,0 | 2 | 39 | 5,0 | KF3510170 | 15,20 | KF3510170ZX3 | 18,00 | | --- |
| 1,80 | 3,0 | 2 | 39 | 5,0 | KF3510180 | 15,20 | KF3510180ZX3 | 18,00 | KF3510180DIA | 54,80 |
| 1,90 | 3,0 | 2 | 39 | 5,0 | KF3510190 | 15,20 | KF3510190ZX3 | 18,00 | | --- |
| 2,00 | 3,0 | 2 | 39 | 5,0 | KF3510200 | 14,40 | KF3510200ZX3 | 17,40 | KF3510200DIA | 54,00 |
| 2,10 | 3,0 | 2 | 39 | 6,0 | KF3510210 | 16,00 | KF3510210ZX3 | 18,80 | KF3510210DIA | 55,60 |
| 2,20 | 3,0 | 2 | 39 | 6,0 | KF3510220 | 16,00 | KF3510220ZX3 | 18,80 | KF3510220DIA | 55,60 |
| 2,30 | 3,0 | 2 | 39 | 6,0 | KF3510230 | 16,00 | KF3510230ZX3 | 18,80 | KF3510230DIA | 55,60 |
| 2,40 | 3,0 | 2 | 39 | 6,0 | KF3510240 | 16,00 | KF3510240ZX3 | 18,80 | KF3510240DIA | 55,60 |
| 2,50 | 3,0 | 2 | 39 | 7,0 | KF3510250 | 16,00 | KF3510250ZX3 | 18,80 | KF3510250DIA | 55,60 |
| 2,60 | 3,0 | 2 | 39 | 7,0 | KF3510260 | 19,00 | KF3510260ZX3 | 21,60 | KF3510260DIA | 48,80 |
| 2,70 | 3,0 | 2 | 39 | 7,0 | KF3510270 | 19,00 | KF3510270ZX3 | 21,60 | KF3510270DIA | 48,80 |
| 2,80 | 3,0 | 2 | 39 | 7,0 | KF3510280 | 19,00 | KF3510280ZX3 | 21,60 | KF3510280DIA | 48,80 |
| 2,90 | 3,0 | 2 | 39 | 7,0 | KF3510290 | 19,00 | KF3510290ZX3 | 21,60 | KF3510290DIA | 48,80 |
| 3,00 | 4,0 | 2 | 44 | 10,0 | KF3510300 | 19,00 | KF3510300ZX3 | 21,00 | KF3510300DIA | 48,80 |

VHM-MICRO-SCHAFTFRÄSER

KF352(5xØ) / KF353(8xØ)



Einsatzgebiete: Universell einsetzbar, sowohl für den Dentalbereich, Kleinstformenbau, Uhren- und Schmuckindustrie sowie zum Fräsen von Elektroden.
Eingriffstiefe bis 8 x Ø.

application: Universal applications. Well suited for dental, jewelry and miniature mould making industry as well as for the machining of electrodes.
Working depth up to 8 x dia.

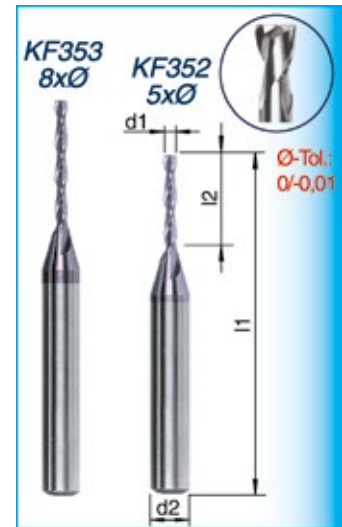

Hinweis/Einsatzempfehlung:

unbeschichtet K15F



ZX3-(TiAlN)-beschichtet



Diamant-beschichtet



- ab Lager / ex stock
- kurzfristig / on short notice
- Lieferzeit ca. 1-2 Wochen / delivery time approx. 1-2 weeks

VHM-Microfräser KF352 - 5xØ

| d1 0/-0,01 | d2 h6 | z | l1 | l2 | Artikel-Nr. unbeschichtet (uncoated) | Preis Euro / je unbeschichtet (uncoated) | Artikel-Nr. (code no.) ZX3 | Preis Euro / je ZX3 | Artikel-Nr. (code no.) Diamant | Preis Euro / je Diamant |
|---------------|----------|---|----|------|--|--|----------------------------------|---------------------------|--------------------------------------|-------------------------------|
| 0,40 | 3,0 | 2 | 39 | 2,0 | KF3520040 | 38,20 | KF3520040ZX3 | 42,40 | KF3520040DIA | 45,00 |
| 0,50 | 3,0 | 2 | 39 | 2,5 | KF3520050 | 34,40 | KF3520050ZX3 | 38,40 | KF3520050DIA | 45,00 |
| 0,60 | 3,0 | 2 | 39 | 3,0 | KF3520060 | 33,40 | KF3520060ZX3 | 37,80 | KF3520060DIA | 45,00 |
| 0,70 | 3,0 | 2 | 39 | 3,5 | KF3520070 | 32,80 | KF3520070ZX3 | 36,80 | KF3520070DIA | 45,00 |
| 0,80 | 3,0 | 2 | 39 | 4,0 | KF3520080 | 32,00 | KF3520080ZX3 | 36,00 | KF3520080DIA | 44,20 |
| 0,90 | 3,0 | 2 | 39 | 4,5 | KF3520090 | 32,00 | KF3520090ZX3 | 36,00 | KF3520090DIA | 44,20 |
| 1,00 | 3,0 | 2 | 39 | 5,0 | KF3520100 | 32,00 | KF3520100ZX3 | 36,00 | KF3520100DIA | 44,20 |
| 1,20 | 3,0 | 2 | 39 | 6,0 | KF3520120 | 32,00 | KF3520120ZX3 | 36,00 | KF3520120DIA | 44,20 |
| 1,50 | 3,0 | 2 | 39 | 7,5 | KF3520150 | 32,00 | KF3520150ZX3 | 36,00 | KF3520150DIA | 49,20 |
| 2,00 | 3,0 | 2 | 39 | 10,0 | KF3520200 | 32,00 | KF3520200ZX3 | 36,00 | KF3520200DIA | 54,00 |

VHM-Microfräser KF353 - 8xØ

| d1 0/-0,01 | d2 h6 | z | l1 | l2 | Artikel-Nr. unbeschichtet (uncoated) | Preis Euro / je unbeschichtet (uncoated) | Artikel-Nr. (code no.) ZX3 | Preis Euro / je ZX3 | Artikel-Nr. (code no.) Diamant | Preis Euro / je Diamant |
|---------------|----------|---|----|------|--|--|----------------------------------|---------------------------|--------------------------------------|-------------------------------|
| 0,50 | 3,0 | 2 | 39 | 4,0 | KF3530050 | 40,40 | KF3530050ZX3 | 48,60 | KF3530050DIA | 70,20 |
| 0,60 | 3,0 | 2 | 39 | 5,0 | KF3530060 | 38,40 | KF3530060ZX3 | 46,80 | KF3530060DIA | 68,20 |
| 0,80 | 3,0 | 2 | 39 | 6,0 | KF3530080 | 38,40 | KF3530080ZX3 | 46,80 | KF3530080DIA | 68,20 |
| 1,00 | 3,0 | 2 | 39 | 8,0 | KF3530100 | 40,40 | KF3530100ZX3 | 48,60 | KF3530100DIA | 70,20 |
| 1,20 | 3,0 | 2 | 39 | 9,0 | KF3530120 | 40,40 | KF3530120ZX3 | 50,20 | KF3530120DIA | 70,20 |
| 1,50 | 4,0 | 2 | 44 | 12,0 | KF3530150 | 49,60 | KF3530150ZX3 | 58,60 | KF3530150DIA | 105,00 |
| 2,00 | 4,0 | 2 | 44 | 16,0 | KF3530200 | 51,20 | KF3530200ZX3 | 61,00 | KF3530200DIA | 106,80 |
| 2,50 | 5,0 | 2 | 60 | 20,0 | KF3530250 | 62,20 | KF3530250ZX3 | 72,80 | | --- |
| 3,00 | 5,0 | 2 | 60 | 24,0 | KF3530300 | 65,80 | KF3530300ZX3 | 75,20 | | --- |

VHM-MICRO-SCHAFTFRÄSER

KF354 (Eingriffstiefe bis 15mm)



Einsatzgebiete: Universell einsetzbar, sowohl für den Dentalbereich, Kleinstformenbau, Uhren- und Schmuckindustrie sowie zum Fräsen von Elektroden. Mit freigestelltem Hals für besonders schwer zugängliche Stellen.

application: Universal applications. Well suited for dental, jewelry and miniature mould making industry as well as for the machining of electrodes.

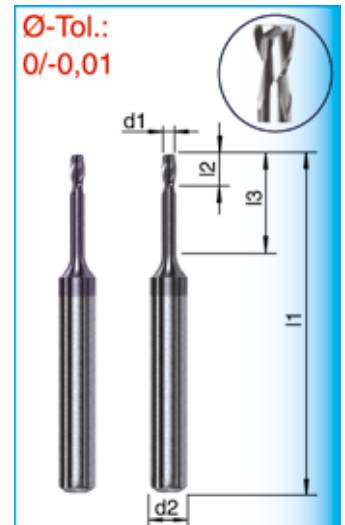

Hinweis/Einsatzempfehlung:

unbeschichtet K15F



ZX3-(TiAlN)-beschichtet



Diamant-beschichtet

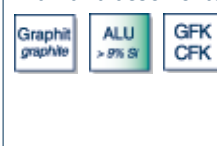

- ab Lager / ex stock
- kurzfristig / on short notice
- Lieferzeit ca. 1-2 Wochen / delivery time approx. 1-2 weeks

| d1 0/-0,01 | d2 h6 | z | l1 | l2 | l3 | Artikel-Nr. unbeschichtet (uncoated) | Preis Euro / je unbeschichtet (uncoated) | Artikel-Nr. (code no.) ZX3 | Preis Euro / je ZX3 | Artikel-Nr. (code no.) Diamant | Preis Euro / je Diamant |
|---------------|----------|---|----|------|----|--|--|----------------------------------|---------------------------|--------------------------------------|-------------------------------|
| 0,40 | 3,0 | 2 | 39 | 0,60 | 2 | KF35400401 | 32,00 | KF35400401ZX | 35,40 | KF35400401DI | 53,80 |
| 0,50 | 3,0 | 2 | 39 | 0,75 | 2 | KF35400501 | 32,00 | KF35400501ZX | 35,40 | KF35400501DI | 53,80 |
| 0,50 | 3,0 | 2 | 39 | 0,75 | 4 | KF35400502 | 32,00 | KF35400502ZX | 35,40 | KF35400502DI | 53,80 |
| 0,50 | 3,0 | 2 | 60 | 0,75 | 6 | KF35400503 | 49,00 | KF35400503ZX | 53,20 | KF35400503DI | 76,80 |
| 0,60 | 3,0 | 2 | 39 | 0,90 | 4 | KF35400601 | 32,00 | KF35400601ZX | 35,40 | KF35400601DI | 53,80 |
| 0,70 | 3,0 | 2 | 39 | 1,05 | 4 | KF35400701 | 32,00 | KF35400701ZX | 35,40 | KF35400701DI | 53,80 |
| 0,80 | 3,0 | 2 | 39 | 1,20 | 4 | KF35400801 | 32,00 | KF35400801ZX | 35,40 | KF35400801DI | 53,80 |
| 0,80 | 3,0 | 2 | 39 | 1,20 | 6 | KF35400802 | 40,60 | KF35400802ZX | 43,80 | KF35400802DI | 63,00 |
| 0,80 | 3,0 | 2 | 60 | 1,20 | 9 | KF35400803 | 49,00 | KF35400803ZX | 53,20 | KF35400803DI | 76,80 |
| 0,90 | 3,0 | 2 | 39 | 1,35 | 6 | KF35400901 | 40,60 | KF35400901ZX | 43,80 | KF35400901DI | 63,00 |
| 1,00 | 3,0 | 2 | 39 | 1,50 | 4 | KF35401001 | 32,00 | KF35401001ZX | 35,40 | KF35401001DI | 53,80 |
| 1,00 | 3,0 | 2 | 39 | 1,50 | 6 | KF35401002 | 32,00 | KF35401002ZX | 35,40 | KF35401002DI | 53,80 |
| 1,00 | 3,0 | 2 | 39 | 1,50 | 9 | KF35401003 | 40,60 | KF35401003ZX | 43,80 | KF35401003DI | 63,00 |
| 1,00 | 3,0 | 2 | 60 | 1,50 | 12 | KF35401004 | 49,00 | KF35401004ZX | 53,20 | KF35401004DI | 76,80 |
| 1,20 | 3,0 | 2 | 39 | 1,80 | 6 | KF35401201 | 32,00 | KF35401201ZX | 35,40 | KF35401201DI | 53,80 |
| 1,20 | 3,0 | 2 | 39 | 1,80 | 9 | KF35401202 | 40,60 | KF35401202ZX | 43,80 | KF35401202DI | 63,00 |
| 1,40 | 3,0 | 2 | 39 | 2,10 | 6 | KF35401401 | 32,00 | KF35401401ZX | 35,40 | KF35401401DI | 53,80 |
| 1,40 | 3,0 | 2 | 39 | 2,10 | 9 | KF35401402 | 40,60 | KF35401402ZX | 43,80 | KF35401402DI | 63,00 |
| 1,50 | 3,0 | 2 | 39 | 2,25 | 6 | KF35401501 | 32,00 | KF35401501ZX | 35,40 | KF35401501DI | 53,80 |
| 1,50 | 3,0 | 2 | 39 | 2,25 | 9 | KF35401502 | 40,60 | KF35401502ZX | 43,80 | KF35401502DI | 63,00 |
| 1,50 | 3,0 | 2 | 60 | 2,25 | 12 | KF35401503 | 49,00 | KF35401503ZX | 53,20 | KF35401503DI | 76,80 |
| 1,80 | 3,0 | 2 | 39 | 2,70 | 9 | KF35401801 | 40,60 | KF35401801ZX | 43,80 | KF35401801DI | 63,00 |
| 1,80 | 3,0 | 2 | 39 | 2,70 | 12 | KF35401802 | 42,00 | KF35401802ZX | 45,40 | KF35401802DI | 64,40 |
| 2,00 | 3,0 | 2 | 39 | 3,00 | 9 | KF35402001 | 40,60 | KF35402001ZX | 43,80 | KF35402001DI | 64,40 |
| 2,00 | 3,0 | 2 | 39 | 3,00 | 12 | KF35402002 | 42,00 | KF35402002ZX | 45,40 | KF35402002DI | 64,40 |
| 2,00 | 3,0 | 2 | 60 | 3,00 | 15 | KF35402003 | 49,00 | KF35402003ZX | 53,20 | KF35402003DI | 76,80 |
| 2,50 | 3,0 | 2 | 60 | 3,00 | 15 | KF35402501 | 49,00 | KF35402501ZX | 53,20 | KF35402501DI | 76,80 |

VHM-MICRO-RADIUSFRÄSER

KFB350 (1,5xØ) / KFB351 (2-3xØ)



Einsatzgebiete: Universell einsetzbar, sowohl für den Dentalbereich, Kleinstformenbau, Uhren- und Schmuckindustrie sowie zum Fräsen von Elektroden.
KFB350 = Extrakurze, stabile Ausführung.

application: Universal applications. Well suited for dental, jewelry and miniature mould making industry as well as for the machining of electrodes.
KFB350 = extra short, stable construction.

Hinweis/Einsatzempfehlung:

| | | | | | | | | |
|---------------------------|--------------------|---------------|---------------------------|----------------------|-------------------------|---------------------|-------------|---------|
| unbeschichtet K15F | | | ZX3-(TiAlN)-beschichtet | | | Diamant-beschichtet | | |
| STAHL steel -3000N/mm² | Kunststoff plastic | ALU aluminium | STAHL steel +1300N/mm² | INOX stainless steel | Titan Inconel Hastelloy | Graphit graphite | ALU > 9% Si | GFK CFK |
| GUSS cast iron | NE non ferrous | Messing brass | HRc 56 | | | | | |



- ab Lager / ex stock
- kurzfristig / on short notice
- Lieferzeit ca. 1-2 Wochen / delivery time approx. 1-2 weeks

VHM-Micro-Radiusfräser KFB350 1,5xØ

| d1 0/-0,01 | d2 h6 | z | l1 | l2 | Artikel-Nr. unbeschichtet (uncoated) | Preis Euro / je unbeschichtet (uncoated) | Artikel-Nr. (code no.) ZX3 | Preis Euro / je ZX3 | Artikel-Nr. (code no.) Diamant | Preis Euro / je Diamant |
|---------------|----------|---|----|------|--|--|----------------------------------|---------------------------|--------------------------------------|-------------------------------|
| 0,10 | 3,0 | 2 | 39 | 0,10 | KFB3500010 | 50,00 | | --- | | --- |
| 0,15 | 3,0 | 2 | 39 | 0,20 | KFB3500015 | 43,40 | | --- | | --- |
| 0,20 | 3,0 | 2 | 39 | 0,30 | KFB3500020 | 39,60 | | --- | | --- |
| 0,25 | 3,0 | 2 | 39 | 0,35 | KFB3500025 | 36,00 | | --- | | --- |
| 0,30 | 3,0 | 2 | 39 | 0,45 | KFB3500030 | 32,60 | KFB3500030ZX | 35,20 | KFB3500030DI | 61,00 |
| 0,40 | 3,0 | 2 | 39 | 0,60 | KFB3500040 | 21,80 | KFB3500040ZX | 24,40 | KFB3500040DI | 46,80 |
| 0,50 | 3,0 | 2 | 39 | 0,75 | KFB3500050 | 18,20 | KFB3500050ZX | 20,80 | KFB3500050DI | 46,80 |
| 0,60 | 3,0 | 2 | 39 | 0,90 | KFB3500060 | 18,20 | KFB3500060ZX | 20,80 | KFB3500060DI | 46,80 |
| 0,70 | 3,0 | 2 | 39 | 1,05 | KFB3500070 | 18,20 | KFB3500070ZX | 20,80 | KFB3500070DI | 46,80 |
| 0,80 | 3,0 | 2 | 39 | 1,20 | KFB3500080 | 18,20 | KFB3500080ZX | 20,80 | KFB3500080DI | 46,80 |
| 0,90 | 3,0 | 2 | 39 | 1,35 | KFB3500090 | 18,20 | KFB3500090ZX | 20,80 | KFB3500090DI | 46,80 |
| 1,00 | 3,0 | 2 | 39 | 1,50 | KFB3500100 | 14,60 | KFB3500100ZX | 17,40 | KFB3500100DI | 46,80 |
| 1,20 | 3,0 | 2 | 39 | 1,80 | KFB3500120 | 18,20 | KFB3500120ZX | 20,80 | KFB3500120DI | 46,80 |
| 1,50 | 3,0 | 2 | 39 | 2,25 | KFB3500150 | 14,60 | KFB3500150ZX | 17,40 | KFB3500150DI | 46,80 |
| 2,00 | 3,0 | 2 | 39 | 3,00 | KFB3500200 | 14,60 | KFB3500200ZX | 17,40 | KFB3500200DI | 56,20 |

VHM-Micro-Radiusfräser KFB351 2-3xØ

| d1 0/-0,01 | d2 h6 | z | l1 | l2 | Artikel-Nr. unbeschichtet (uncoated) | Preis Euro / je unbeschichtet (uncoated) | Artikel-Nr. (code no.) ZX3 | Preis Euro / je ZX3 | Artikel-Nr. (code no.) Diamant | Preis Euro / je Diamant |
|---------------|----------|---|----|------|--|--|----------------------------------|---------------------------|--------------------------------------|-------------------------------|
| 0,10 | 3,0 | 2 | 39 | 0,2 | KFB3510010 | 50,00 | | --- | | --- |
| 0,15 | 3,0 | 2 | 39 | 0,3 | KFB3510015 | 43,40 | | --- | | --- |
| 0,20 | 3,0 | 2 | 39 | 0,5 | KFB3510020 | 39,60 | | --- | | --- |
| 0,25 | 3,0 | 2 | 39 | 0,5 | KFB3510025 | 36,00 | | --- | | --- |
| 0,30 | 3,0 | 2 | 39 | 1,0 | KFB3510030 | 32,60 | KFB3510030ZX | 35,20 | KFB3510030DI | 61,00 |
| 0,35 | 3,0 | 2 | 39 | 1,0 | KFB3510035 | 28,80 | KFB3510035ZX | 31,60 | KFB3510035DI | --- |
| 0,40 | 3,0 | 2 | 39 | 1,0 | KFB3510040 | 21,80 | KFB3510040ZX | 24,40 | KFB3510040DI | 46,80 |
| 0,50 | 3,0 | 2 | 39 | 1,5 | KFB3510050 | 18,20 | KFB3510050ZX | 20,80 | KFB3510050DI | 46,80 |
| 0,60 | 3,0 | 2 | 39 | 1,5 | KFB3510060 | 18,20 | KFB3510060ZX | 20,80 | KFB3510060DI | 46,80 |
| 0,70 | 3,0 | 2 | 39 | 2,0 | KFB3510070 | 18,20 | KFB3510070ZX | 20,80 | KFB3510070DI | 46,80 |
| 0,80 | 3,0 | 2 | 39 | 2,0 | KFB3510080 | 18,20 | KFB3510080ZX | 20,80 | KFB3510080DI | 46,80 |
| 0,90 | 3,0 | 2 | 39 | 2,5 | KFB3510090 | 18,20 | KFB3510090ZX | 20,80 | KFB3510090DI | 46,80 |
| 1,00 | 3,0 | 2 | 39 | 3,0 | KFB3510100 | 14,60 | KFB3510100ZX | 17,40 | KFB3510100DI | 46,80 |
| 1,10 | 3,0 | 2 | 39 | 3,0 | KFB3510110 | 18,20 | KFB3510110ZX | 20,80 | KFB3510110DI | --- |
| 1,20 | 3,0 | 2 | 39 | 1,8 | KFB3500120 | 18,20 | KFB3500120ZX | 20,80 | KFB3500120DI | 46,80 |
| 1,40 | 3,0 | 2 | 39 | 4,0 | KFB3510140 | 18,20 | KFB3510140ZX | 20,80 | KFB3510140DI | 46,80 |
| 1,50 | 3,0 | 2 | 39 | 2,3 | KFB3500150 | 14,60 | KFB3500150ZX | 17,40 | KFB3500150DI | 46,80 |
| 1,60 | 3,0 | 2 | 39 | 4,0 | KFB3510160 | 18,20 | KFB3510160ZX | 20,80 | KFB3510160DI | 56,20 |
| 1,80 | 3,0 | 2 | 39 | 5,0 | KFB3510180 | 18,20 | KFB3510180ZX | 20,80 | KFB3510180DI | 56,20 |
| 2,00 | 3,0 | 2 | 39 | 3,0 | KFB3500200 | 14,60 | KFB3500200ZX | 17,40 | KFB3500200DI | 56,20 |
| 2,50 | 3,0 | 2 | 39 | 7,0 | KFB3510250 | 18,20 | KFB3512500ZX | 20,80 | KFB3510250DI | 56,20 |
| 3,00 | 4,0 | 2 | 44 | 10,0 | KFB3510300 | 19,80 | KFB3510300ZX | 22,00 | KFB3510300DI | 50,40 |

VHM-MICRO-RADIUSFRÄSER

KFB352 (Eingriffstiefe bis 15mm)



Einsatzgebiete: Universell einsetzbar, sowohl für den Dentalbereich, Kleinstformenbau, Uhren- und Schmuckindustrie sowie zum Fräsen von Elektroden. Mit freigestelltem Hals für besonders schwer zugängliche Stellen.

application: Universal applications. Well suited for dental, jewelry and miniature mould making industry as well as for the machining of electrodes.

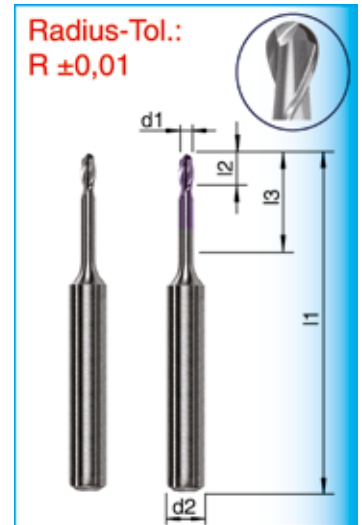

Hinweis/Einsatzempfehlung:

| | | | | | | | | |
|-------------------------------|-----------------------|------------------|-------------------------------|-------------------------|-------------------------------|---------------------|----------------|------------|
| unbeschichtet K15F | | | ZX3-(TiAlN)-beschichtet | | | Diamant-beschichtet | | |
| STAHL steeel +1300N/mm² | Kunststoff plastic | ALU aluminium | STAHL steeel +1300N/mm² | INOX stainless steel | Titan Inconel Hastelloy | Graphit graphite | ALU > 9% Si | GFK CFK |
| GUSS cast iron | NE non ferrous | Messing brass | HRC 56 | | | | | |

- ab Lager / ex stock
- kurzfristig / on short notice
- Lieferzeit ca. 1-2 Wochen / delivery time approx. 1-2 weeks

| d1 0/-0,01 | d2 h6 | z | l1 | l2 | l3 | Artikel-Nr. unbeschichtet (uncoated) | Preis Euro / je unbeschichtet (uncoated) | Artikel-Nr. (code no.) ZX3 | Preis Euro / je ZX3 | Artikel-Nr. (code no.) Diamant | Preis Euro / je Diamant |
|---------------|----------|---|----|------|----|--|--|----------------------------------|---------------------------|--------------------------------------|-------------------------------|
| 0,40 | 3,0 | 2 | 39 | 0,60 | 2 | KFB35200401 | 36,80 | KFB35200401Z | 40,20 | KFB35200401D | 62,80 |
| 0,50 | 3,0 | 2 | 39 | 0,75 | 2 | KFB35200501 | 36,80 | KFB35200501Z | 40,20 | KFB35200501D | 62,80 |
| 0,50 | 3,0 | 2 | 39 | 0,75 | 4 | KFB35200502 | 36,80 | KFB35200502Z | 40,20 | KFB35200502D | 62,80 |
| 0,50 | 3,0 | 2 | 60 | 0,75 | 6 | KFB35200503 | 55,00 | KFB35200503Z | 58,80 | KFB35200503D | 88,40 |
| 0,60 | 3,0 | 2 | 39 | 0,90 | 4 | KFB35200601 | 36,80 | KFB35200601Z | 40,20 | KFB35200601D | 62,80 |
| 0,80 | 3,0 | 2 | 39 | 1,20 | 4 | KFB35200801 | 36,80 | KFB35200801Z | 40,20 | KFB35200801D | 62,80 |
| 0,80 | 3,0 | 2 | 39 | 1,20 | 6 | KFB35200802 | 46,80 | KFB35200802Z | 49,80 | KFB35200802D | 74,20 |
| 0,80 | 3,0 | 2 | 60 | 1,20 | 9 | KFB35200803 | 55,00 | KFB35200803Z | 58,80 | KFB35200803D | 88,40 |
| 1,00 | 3,0 | 2 | 39 | 1,50 | 4 | KFB35201001 | 36,80 | KFB35201001Z | 40,20 | KFB35201001D | 62,80 |
| 1,00 | 3,0 | 2 | 39 | 1,50 | 6 | KFB35201002 | 36,80 | KFB35201002Z | 40,20 | KFB35201002D | 62,80 |
| 1,00 | 3,0 | 2 | 39 | 1,50 | 9 | KFB35201003 | 46,80 | KFB35201003Z | 49,80 | KFB35201003D | 74,20 |
| 1,00 | 3,0 | 2 | 60 | 1,50 | 12 | KFB35201004 | 55,00 | KFB35201004Z | 58,80 | KFB35201004D | 88,40 |
| 1,20 | 3,0 | 2 | 39 | 1,80 | 6 | KFB35201201 | 36,80 | KFB35201201Z | 40,20 | KFB35201201D | 62,80 |
| 1,50 | 3,0 | 2 | 39 | 2,25 | 6 | KFB35201501 | 36,80 | KFB35201501Z | 40,20 | KFB35201501D | 62,80 |
| 1,50 | 3,0 | 2 | 39 | 2,25 | 9 | KFB35201502 | 46,80 | KFB35201502Z | 49,80 | KFB35201502D | 74,20 |
| 1,50 | 3,0 | 2 | 60 | 2,25 | 12 | KFB35201503 | 55,00 | KFB35201503Z | 58,80 | KFB35201503D | 88,40 |
| 2,00 | 3,0 | 2 | 39 | 3,00 | 9 | KFB35202001 | 46,80 | KFB35202001Z | 49,80 | KFB35202001D | 74,20 |
| 2,00 | 3,0 | 2 | 39 | 3,00 | 12 | KFB35202002 | 46,80 | KFB35202002Z | 49,80 | KFB35202002D | 74,20 |
| 2,00 | 3,0 | 2 | 60 | 3,00 | 15 | KFB35202003 | 55,00 | KFB35202003Z | 58,80 | KFB35202003D | 88,40 |
| 2,50 | 3,0 | 2 | 60 | 3,75 | 15 | KFB35202501 | 55,00 | KFB35202501Z | 58,80 | KFB35202501D | 88,40 |

VHM-MICRO-1/4-KREIS KONKAVFRÄSER

KF616



Einsatzgebiete: Micro-1/4-Kreis-Fräser aus Vollhartmetall. Der Radius (R) ist auf den kleinen Ø (d1) ausgerichtet und ermöglicht die präzise Bearbeitung komplexer Formen, kleinster Bohrungen und Nuten ab Ø 0,5mm.

application: CNC-micro-round-corner-cutters. Radius (R) is aligned with the small Ø (d1) which makes it possible to precisely machine complex forms and small slots starting at Ø 0.5mm.

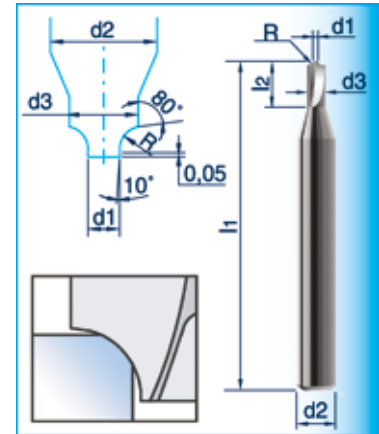

- ab Lager / ex stock
- kurzfristig / on short notice
- Lieferzeit auf Anfrage / delivery time upon request

| Radius R ±0,02 mm | d1 ±0,10 mm | d2 h6 mm | d3 mm | l1 mm | l2 mm | Zähnezahl (no. of cutting edges) | Artikel-Nr. (code no.) | Preis Euro / je KF616 |
|-------------------------|-------------------|----------------|----------|----------|----------|--|---------------------------|-----------------------------|
| • 0,10 | 0,5 | 3,0 | 0,8 | 50 | 2,5 | 2 | KF6160010 | 37,00 |
| • 0,15 | 0,5 | 3,0 | 0,9 | 50 | 2,5 | 2 | KF6160015 | 37,00 |
| • 0,20 | 0,5 | 3,0 | 1,0 | 50 | 2,5 | 2 | KF6160020 | 37,00 |
| • 0,25 | 0,5 | 3,0 | 1,0 | 50 | 2,5 | 2 | KF6160025 | 30,00 |
| • 0,30 | 0,5 | 3,0 | 1,2 | 50 | 2,5 | 2 | KF6160030 | 30,00 |
| • 0,40 | 0,5 | 3,0 | 1,4 | 50 | 2,5 | 2 | KF6160040 | 30,00 |
| • 0,50 | 0,5 | 3,0 | 1,6 | 50 | 2,5 | 2 | KF6160050 | 30,00 |
| • 0,60 | 0,5 | 3,0 | 1,8 | 50 | 3,0 | 2 | KF6160060 | 30,00 |
| • 0,70 | 0,5 | 3,0 | 2,1 | 50 | 3,0 | 2 | KF6160070 | 30,00 |
| • 0,75 | 0,5 | 3,0 | 2,1 | 50 | 3,0 | 2 | KF6160075 | 30,00 |
| • 0,80 | 0,8 | 3,0 | 2,5 | 50 | 4,0 | 2 | KF6160080 | 30,00 |
| • 0,90 | 0,8 | 3,0 | 2,9 | 50 | 4,0 | 2 | KF6160090 | 30,00 |
| • 1,00 | 0,8 | 3,0 | 2,9 | 50 | 4,0 | 2 | KF6160100 | 30,00 |
| • 1,25 | 0,8 | 4,0 | 3,4 | 50 | 4,0 | 2 | KF6160125 | 37,00 |
| • 1,50 | 1,5 | 5,0 | 4,6 | 50 | 6,0 | 2 | KF6160150 | 37,00 |
| • 1,75 | 1,5 | 6,0 | 5,6 | 50 | 6,0 | 2 | KF6160175 | 37,00 |
| • 2,00 | 1,5 | 6,0 | 5,6 | 50 | 8,0 | 2 | KF6160200 | 37,00 |
| • 2,25 | 1,5 | 8,0 | 6,6 | 50 | 10,0 | 2 | KF6160225 | 47,60 |
| • 2,50 | 1,5 | 8,0 | 6,6 | 50 | 10,0 | 2 | KF6160250 | 47,60 |
| • 3,00 | 1,5 | 8,0 | 6,6 | 50 | 10,0 | 2 | KF6160300 | 47,60 |
| • 4,00 | 1,9 | 10,0 | 10,0 | 55 | - | 2 | KF6160400 | 73,80 |
| • 5,00 | 1,9 | 12,0 | 12,0 | 63 | - | 2 | KF6160500 | 88,80 |

Beschichtungsvarianten



| Material | TIALN | TIALN | TIALN | TICN | DIAMANT |
|--|--------------|--------------|-------------|-----------|---------|
| Mikrohärte (HV 0,05) | 3000 | 3500 | 3300 | 3000 | 10000 |
| Max. Anwendungs- Temperatur (°C) | 800 | 800 | 800 | 400 | 700 |
| Schichtfarbe | violett-grau | violett-grau | rot-violett | blau-grau | grau |

VHM-RADIUSFRÄSER 30°

KFB... - ZX1

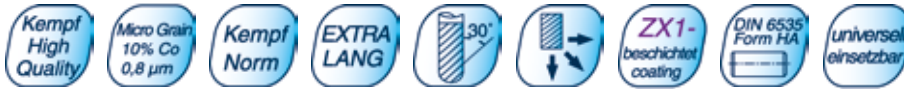

Einsatzgebiete: Universell einsetzbar, sowohl für hochfeste Werkstoffe als auch für Alu und NE-Metalle geeignet. Wahlweise unbeschichtet oder mit ZX1-Beschichtung.

application: Universal applications. Suitable for high hard materials as well as aluminium and nonferrous metals. Available uncoated or with ZX1-coating.

- KFB330 = 2 Schneiden mit Zentrumschnitt / 2 cutting edges, center cutting
- KFB362 = 3 Schneiden mit Zentrumschnitt / 3 cutting edges, center cutting
- KFB320 = 4 Schneiden mit Zentrumschnitt / 4 cutting edges, center cutting
- KFB382 = 2 Schneiden mit Zentrumschnitt EXTRA LANG / 2 cut. ed., center cutting EXTRA L.
- KFB383 = 3 Schneiden mit Zentrumschnitt EXTRA LANG / 3 cut. ed., center cutting EXTRA LONG
- KFB384 = 4 Schneiden mit Zentrumschnitt EXTRA LANG / 4 cut. ed., center cutting EXTRA LONG



- ab Lager / ex stock
- kurzfristig / on short notice
- Lieferzeit auf Anfrage / delivery time upon request

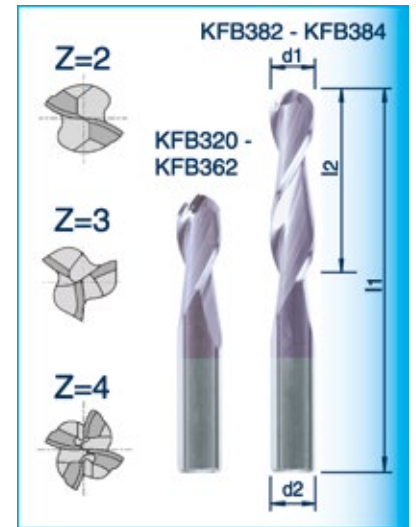

VHM-Radiusfräser Werknorm

| d1 | d2 | l2 | l1 | Artikel-Nr. | Artikel-Nr. | Artikel-Nr. | Preis | Artikel-Nr. | Artikel-Nr. | Artikel-Nr. | Preis | |
|-----|------|------|------|-------------|-------------|-------------|---------------------------------|---|-----------------|-----------------|--------------|--------|
| h10 | h6 | | | 2-Schneidig | 3-Schneidig | 4-Schneidig | Euro / je | 2-Schneidig | 3-Schneidig | 4-Schneidig | Euro / je | |
| mm | mm | mm | mm | (code no.) | (code no.) | (code no.) | unbesch. | (code no.) | (code no.) | (code no.) | ZX1 - besch. | |
| | | | | | | | 2 cutting edges (uncoated) | 2 cutting edges | 3 cutting edges | 4 cutting edges | ZX1 - coated | |
| | | | | | | | Fräser unbeschichtet (uncoated) | Fräser ZX1 - beschichtet (ZX1 - coated) | | | | |
| • | 1,0 | 3,0 | 3,0 | 38 | KFB330010 | KFB362010 | KFB320010 | 10,60 | KFB330010ZX1 | KFB362010ZX1 | KFB320010ZX1 | 12,60 |
| • | 1,5 | 3,0 | 4,5 | 38 | KFB330015 | KFB362015 | KFB320015 | 10,00 | KFB330015ZX1 | KFB362015ZX1 | KFB320015ZX1 | 11,80 |
| • | 2,0 | 3,0 | 6,3 | 38 | KFB330020 | KFB362020 | KFB320020 | 10,00 | KFB330020ZX1 | KFB362020ZX1 | KFB320020ZX1 | 11,80 |
| • | 2,5 | 3,0 | 9,5 | 38 | KFB330025 | KFB362025 | KFB320025 | 9,60 | KFB330025ZX1 | KFB362025ZX1 | KFB320025ZX1 | 11,40 |
| • | 3,0 | 3,0 | 12,0 | 38 | KFB330030 | KFB362030 | KFB320030 | 9,00 | KFB330030ZX1 | KFB362030ZX1 | KFB320030ZX1 | 10,60 |
| • | 4,0 | 4,0 | 14,0 | 50 | KFB330040 | KFB362040 | KFB320040 | 13,00 | KFB330040ZX1 | KFB362040ZX1 | KFB320040ZX1 | 15,20 |
| • | 5,0 | 5,0 | 16,0 | 50 | KFB330050 | KFB362050 | KFB320050 | 14,40 | KFB330050ZX1 | KFB362050ZX1 | KFB320050ZX1 | 17,80 |
| • | 6,0 | 6,0 | 19,0 | 50 | KFB330060 | KFB362060 | KFB320060 | 14,80 | KFB330060ZX1 | KFB362060ZX1 | KFB320060ZX1 | 18,20 |
| • | 7,0 | 7,0 | 20,0 | 60 | KFB330070 | KFB362070 | KFB320070 | 20,40 | KFB330070ZX1 | KFB362070ZX1 | KFB320070ZX1 | 25,60 |
| • | 8,0 | 8,0 | 20,0 | 63 | KFB330080 | KFB362080 | KFB320080 | 20,60 | KFB330080ZX1 | KFB362080ZX1 | KFB320080ZX1 | 26,40 |
| • | 9,0 | 9,0 | 22,0 | 63 | KFB330090 | KFB362090 | KFB320090 | 28,00 | KFB330090ZX1 | KFB362090ZX1 | KFB320090ZX1 | 33,40 |
| • | 10,0 | 10,0 | 22,0 | 70 | KFB330100 | KFB362100 | KFB320100 | 33,60 | KFB330100ZX1 | KFB362100ZX1 | KFB320100ZX1 | 41,00 |
| • | 12,0 | 12,0 | 25,0 | 76 | KFB330120 | KFB362120 | KFB320120 | 39,80 | KFB330120ZX1 | KFB362120ZX1 | KFB320120ZX1 | 47,40 |
| • | 14,0 | 14,0 | 32,0 | 89 | KFB330140 | KFB362140 | KFB320140 | 70,20 | KFB330140ZX1 | KFB362140ZX1 | KFB320140ZX1 | 81,00 |
| • | 16,0 | 16,0 | 38,0 | 89 | KFB330160 | KFB362160 | KFB320160 | 76,00 | KFB330160ZX1 | KFB362160ZX1 | KFB320160ZX1 | 89,60 |
| • | 18,0 | 18,0 | 38,0 | 101 | KFB330180 | KFB362180 | KFB320180 | 124,80 | KFB330180ZX1 | KFB362180ZX1 | KFB320180ZX1 | 138,60 |
| • | 20,0 | 20,0 | 38,0 | 101 | KFB330200 | KFB362200 | KFB320200 | 143,60 | KFB330200ZX1 | KFB362200ZX1 | KFB320200ZX1 | 159,40 |
| • | 25,0 | 25,0 | 38,0 | 101 | KFB330250 | KFB362250 | KFB320250 | 179,40 | KFB330250ZX1 | KFB362250ZX1 | KFB320250ZX1 | 200,20 |

VHM-Radiusfräser EXTRA LANG

| d1 | d2 | l2 | l1 | Artikel-Nr. | Artikel-Nr. | Artikel-Nr. | Preis | Artikel-Nr. | Artikel-Nr. | Artikel-Nr. | Preis | |
|-----|------|------|------|-------------|-------------|-------------|---------------------------------|---|-----------------|-----------------|--------------|--------|
| h10 | h6 | | | 2-Schneidig | 3-Schneidig | 4-Schneidig | Euro / je | 2-Schneidig | 3-Schneidig | 4-Schneidig | Euro / je | |
| mm | mm | mm | mm | (code no.) | (code no.) | (code no.) | unbesch. | (code no.) | (code no.) | (code no.) | ZX1 - besch. | |
| | | | | | | | 2 cutting edges (uncoated) | 2 cutting edges | 3 cutting edges | 4 cutting edges | ZX1 - coated | |
| | | | | | | | Fräser unbeschichtet (uncoated) | Fräser ZX1 - beschichtet (ZX1 - coated) | | | | |
| • | 3,0 | 3,0 | 25,0 | 76 | KFB382030 | KFB383030 | KFB384030 | 18,20 | KFB382030ZX1 | KFB383030ZX1 | KFB384030ZX1 | 20,80 |
| • | 4,0 | 4,0 | 28,0 | 76 | KFB382040 | KFB383040 | KFB384040 | 20,80 | KFB382040ZX1 | KFB383040ZX1 | KFB384040ZX1 | 24,00 |
| • | 5,0 | 5,0 | 32,0 | 76 | KFB382050 | KFB383050 | KFB384050 | 24,40 | KFB382050ZX1 | KFB383050ZX1 | KFB384050ZX1 | 28,60 |
| • | 6,0 | 6,0 | 38,0 | 76 | KFB382060 | KFB383060 | KFB384060 | 25,60 | KFB382060ZX1 | KFB383060ZX1 | KFB384060ZX1 | 29,80 |
| • | 8,0 | 8,0 | 40,0 | 101 | KFB382080 | KFB383080 | KFB384080 | 33,20 | KFB382080ZX1 | KFB383080ZX1 | KFB384080ZX1 | 40,60 |
| • | 10,0 | 10,0 | 50,0 | 101 | KFB382100 | KFB383100 | KFB384100 | 52,00 | KFB382100ZX1 | KFB383100ZX1 | KFB384100ZX1 | 61,60 |
| • | 12,0 | 12,0 | 50,0 | 101 | KFB382120 | KFB383120 | KFB384120 | 56,20 | KFB382120ZX1 | KFB383120ZX1 | KFB384120ZX1 | 66,40 |
| • | 16,0 | 16,0 | 64,0 | 127 | KFB382160 | KFB383160 | KFB384160 | 124,20 | KFB382160ZX1 | KFB383160ZX1 | KFB384160ZX1 | 144,80 |
| • | 20,0 | 20,0 | 76,0 | 152 | KFB382200 | KFB383200 | KFB384200 | 258,40 | KFB382200ZX1 | KFB383200ZX1 | KFB384200ZX1 | 283,00 |
| • | 25,0 | 25,0 | 76,0 | 152 | KFB382250 | KFB383250 | KFB384250 | 303,40 | KFB382250ZX1 | KFB383250ZX1 | KFB384250ZX1 | 331,20 |

VHM-HSC-KOPIERFRÄSER 30°

KFB502 / KFB503 - ZX3



Einsatzgebiete: Werkzeug und Hartmetall wurden speziell für die HSC- und Hartbearbeitung im Werkzeug- und Formenbau entwickelt. Hervorragend geeignet für die Trockenbearbeitung.

application: This tool and carbide grade were developed especially for high-speed and high-hard operations in tool making and die- and mould-making. Excellent suited for dry machining.

| * Durchmesser-toleranz (Ø-tolerance) „e8“: | | | | |
|--|-----------------|-----------------|-----------------|-----------------|
| Ø 1 - Ø 3 | Ø 3 - Ø 6 | Ø 6 - Ø 10 | Ø 10 - Ø 18 | Ø 18 - Ø 25 |
| -0,014 / -0,028 | -0,020 / -0,038 | -0,025 / -0,047 | -0,032 / -0,059 | -0,040 / -0,073 |



KFB502 = kurze und lange Ausführung
KFB503 = EXTRA LANGE Ausführung

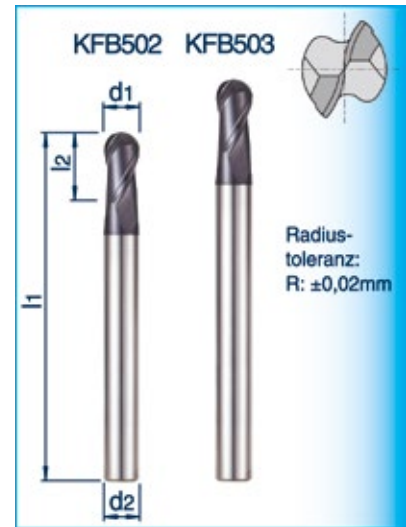

- ab Lager / ex stock
- kurzfristig / on short notice
- Lieferzeit auf Anfrage / delivery time upon request

VHM-Kopierfräser KFB502 - kurze und lange Ausführung

| d1 e8* mm | d2 h6 mm | l2 mm | l1 mm | Zähnezahl (no. of cutting edges) | Artikel-Nr. (code no.) | Preis Euro / je KFB502 - ZX3 |
|-----------------|----------------|----------|----------|--|---------------------------|------------------------------------|
| • 1,0 | 4,0 | 2,5 | 50 | 2 | KFB502010ZX3 | 18,80 |
| • 1,2 | 4,0 | 3,0 | 50 | 2 | KFB502012ZX3 | 18,80 |
| • 1,5 | 4,0 | 4,0 | 50 | 2 | KFB502015ZX3 | 18,80 |
| • 2,0 | 6,0 | 3,0 | 50 | 2 | KFB502020ZXK | 16,80 |
| • 2,0 | 6,0 | 5,0 | 50 | 2 | KFB502020ZX3 | 18,00 |
| • 3,0 | 6,0 | 4,0 | 50 | 2 | KFB502030ZXK | 16,80 |
| • 3,0 | 6,0 | 8,0 | 60 | 2 | KFB502030ZX3 | 18,00 |
| • 4,0 | 6,0 | 5,0 | 54 | 2 | KFB502040ZXK | 17,60 |
| • 4,0 | 6,0 | 8,0 | 70 | 2 | KFB502040ZX3 | 18,80 |
| • 5,0 | 6,0 | 6,0 | 54 | 2 | KFB502050ZXK | 17,60 |
| • 5,0 | 6,0 | 10,0 | 80 | 2 | KFB502050ZX3 | 19,40 |
| • 6,0 | 6,0 | 7,0 | 54 | 2 | KFB502060ZXK | 17,60 |
| • 6,0 | 6,0 | 12,0 | 90 | 2 | KFB502060ZX3 | 21,00 |
| • 7,0 | 8,0 | 9,0 | 58 | 2 | KFB502070ZXK | 28,00 |
| • 7,0 | 8,0 | 14,0 | 90 | 2 | KFB502070ZX3 | 32,80 |
| • 8,0 | 8,0 | 9,0 | 58 | 2 | KFB502080ZXK | 28,00 |
| • 8,0 | 8,0 | 14,0 | 100 | 2 | KFB502080ZX3 | 32,80 |
| • 9,0 | 10,0 | 10,0 | 66 | 2 | KFB502090ZXK | 43,60 |
| • 9,0 | 10,0 | 18,0 | 100 | 2 | KFB502090ZX3 | 52,00 |
| • 10,0 | 10,0 | 11,0 | 66 | 2 | KFB502100ZXK | 43,60 |
| • 10,0 | 10,0 | 18,0 | 100 | 2 | KFB502100ZX3 | 52,00 |
| • 12,0 | 12,0 | 12,0 | 73 | 2 | KFB502120ZXK | 55,00 |
| • 12,0 | 12,0 | 22,0 | 110 | 2 | KFB502120ZX3 | 66,40 |
| • 14,0 | 14,0 | 14,0 | 75 | 2 | KFB502140ZXK | 66,40 |
| • 14,0 | 14,0 | 26,0 | 110 | 2 | KFB502140ZX3 | 83,40 |
| • 16,0 | 16,0 | 16,0 | 82 | 2 | KFB502160ZXK | 86,20 |
| • 16,0 | 16,0 | 30,0 | 140 | 2 | KFB502160ZX3 | 110,20 |
| • 18,0 | 18,0 | 18,0 | 84 | 2 | KFB502180ZXK | 91,80 |
| • 18,0 | 18,0 | 34,0 | 140 | 2 | KFB502180ZX3 | 110,00 |
| • 20,0 | 20,0 | 20,0 | 92 | 2 | KFB502200ZXK | 124,20 |
| • 20,0 | 20,0 | 38,0 | 160 | 2 | KFB502200ZX3 | 172,00 |
| • 25,0 | 25,0 | 25,0 | 104 | 2 | KFB502250ZXK | 216,20 |
| • 25,0 | 25,0 | 50,0 | 180 | 2 | KFB502250ZX3 | 275,20 |

VHM-Kopierfräser KFB503 - EXTRA LANGE Ausführung

| d1 e8* mm | d2 h6 mm | l2 mm | l1 mm | Zähnezahl (no. of cutting edges) | Artikel-Nr. (code no.) | Preis Euro / je KFB503 - ZX3 |
|-----------------|----------------|----------|----------|--|---------------------------|------------------------------------|
| • 2,0 | 3,0 | 6,0 | 80 | 2 | KFB503020ZX3 | 25,20 |
| • 3,0 | 3,0 | 8,0 | 100 | 2 | KFB503030ZX3 | 25,20 |
| • 4,0 | 4,0 | 8,0 | 100 | 2 | KFB503040ZX3 | 25,20 |
| • 5,0 | 6,0 | 10,0 | 120 | 2 | KFB503050ZX3 | 27,20 |
| • 6,0 | 6,0 | 10,0 | 120 | 2 | KFB503060ZX3 | 27,20 |
| • 8,0 | 8,0 | 14,0 | 140 | 2 | KFB503080ZX3 | 44,00 |
| • 10,0 | 10,0 | 18,0 | 180 | 2 | KFB503100ZX3 | 83,40 |
| • 12,0 | 12,0 | 22,0 | 200 | 2 | KFB503120ZX3 | 106,20 |
| • 16,0 | 16,0 | 30,0 | 250 | 2 | KFB503160ZX3 | 181,80 |
| • 20,0 | 20,0 | 38,0 | 250 | 2 | KFB503200ZX3 | 283,40 |

VHM-HSC-KOPIERFRÄSER HRc55 bis HRc65

KFB516 - ZX3



Einsatzgebiete: Werkzeug und Hartmetall wurden speziell für die HSC- und Hartbearbeitung im Werkzeug- und Formenbau entwickelt. Hervorragend geeignet für die Trockenbearbeitung.

application: This tool and carbide grade were developed especially for high-speed and high-hard operations in tool making and die- and mould-making. Excellent suited for dry machining.

* Durchmesser-toleranz (Ø-tolerance) „e8“:

| | | | | |
|-----------------|-----------------|-----------------|-----------------|-----------------|
| Ø 1 - Ø 3 | Ø 3 - Ø 6 | Ø 6 - Ø 10 | Ø 10 - Ø 18 | Ø 18 - Ø 25 |
| -0,014 / -0,028 | -0,020 / -0,038 | -0,025 / -0,047 | -0,032 / -0,059 | -0,040 / -0,073 |

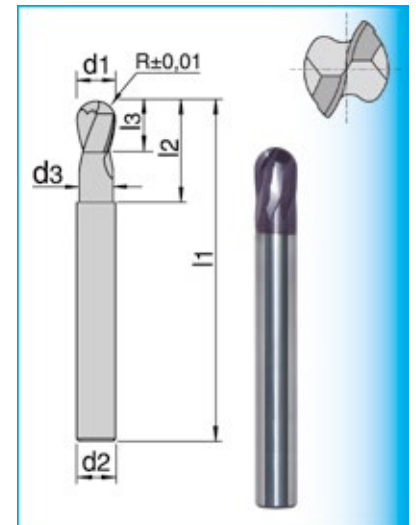

- ab Lager / ex stock
- kurzfristig / on short notice
- Lieferzeit auf Anfrage / delivery time upon request

| | d1 e8 mm | d2 h6 mm | d3 mm | l3 mm | l2 mm | l1 mm | Zähnezahl (no. of cutting edges) | Artikel-Nr. (code no.) | Preis Euro / je KFB516 - ZX3 |
|---|----------------|----------------|----------|----------|----------|----------|--|---------------------------|------------------------------------|
| • | 1,0 | 4 | 0,95 | 1,0 | 2,2 | 50 | 2 | KFB516010ZX3 | 23,40 |
| • | 1,2 | 4 | 1,10 | 1,2 | 2,6 | 50 | 2 | KFB516012ZX3 | 23,40 |
| • | 1,5 | 4 | 1,40 | 1,5 | 3,0 | 50 | 2 | KFB516015ZX3 | 23,40 |
| • | 2,0 | 6 | 1,90 | 2,0 | 4,0 | 50 | 2 | KFB516020ZX3 | 22,20 |
| • | 3,0 | 6 | 2,90 | 3,0 | 6,0 | 60 | 2 | KFB516030ZX3 | 22,20 |
| • | 4,0 | 6 | 3,90 | 4,0 | 8,0 | 70 | 2 | KFB516040ZX3 | 23,00 |
| • | 5,0 | 6 | 4,90 | 5,0 | 10,0 | 80 | 2 | KFB516050ZX3 | 23,80 |
| • | 6,0 | 6 | 5,90 | 6,0 | 12,0 | 90 | 2 | KFB516060ZX3 | 25,60 |
| • | 7,0 | 8 | 6,90 | 7,0 | 14,0 | 90 | 2 | KFB516070ZX3 | 40,40 |
| • | 8,0 | 8 | 7,90 | 8,0 | 16,0 | 100 | 2 | KFB516080ZX3 | 40,20 |
| • | 9,0 | 10 | 8,90 | 9,0 | 18,0 | 100 | 2 | KFB516090ZX3 | 65,20 |
| • | 10,0 | 10 | 9,90 | 10,0 | 20,0 | 100 | 2 | KFB516100ZX3 | 65,20 |
| • | 12,0 | 12 | 11,90 | 12,0 | 24,0 | 110 | 2 | KFB516120ZX3 | 83,60 |
| • | 14,0 | 14 | 13,80 | 14,0 | 28,0 | 110 | 2 | KFB516140ZX3 | 105,40 |
| • | 16,0 | 16 | 15,80 | 16,0 | 32,0 | 140 | 2 | KFB516160ZX3 | 139,20 |
| • | 18,0 | 18 | 17,80 | 18,0 | 36,0 | 140 | 2 | KFB516180ZX3 | 151,00 |
| • | 20,0 | 20 | 19,80 | 20,0 | 40,0 | 160 | 2 | KFB516200ZX3 | 214,40 |
| • | 25,0 | 25 | 24,80 | 25,0 | 50,0 | 180 | 2 | KFB516250ZX3 | 346,00 |

VHM-HSC-KOPIERFRÄSER (zylindrisch abgesetzt)

KFB506 - ZX3



Einsatzgebiete: Werkzeug und Hartmetall wurden speziell für die HSC- und Hartbearbeitung im Werkzeug- und Formenbau entwickelt. Hervorragend geeignet für die Trockenbearbeitung.

application: This tool and carbide grade were developed especially for high-speed and high-hard operations in tool making and die- and mould-making. Excellent suited for dry machining.

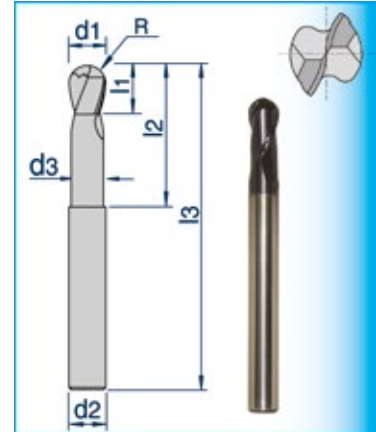

| Ø-Toleranz für d1***: | |
|-----------------------|------------|
| Ø 1 - Ø 6 | Ø 6 - Ø 25 |
| 0 / -0,028 | 0 / -0,038 |

| Radiustoleranz Typ KFB506: | |
|------------------------------|--------------------------|
| <math>< \text{Ø } 6,5</math> | > $\text{Ø } 6,5</math>$ |
| $\pm 0,01$ | $\pm 0,02$ |

- ab Lager / ex stock
- kurzfristig / on short notice
- Lieferzeit auf Anfrage / delivery time upon request

| d1 *** mm | R | d2 h6 mm | d3 mm | l1 mm | l2 mm | l3 mm | Artikel-Nr. (code no.) | Preis Euro / je KFB506 - ZX3 |
|-----------------|-------|----------------|----------|----------|----------|----------|---------------------------|------------------------------------|
| • 3,0 | R1,5 | 6 | - | 8 | - | 70 | KFB506030ZX3 | 22,40 |
| • 4,0 | R2,0 | 6 | - | 8 | - | 70 | KFB506040ZX3 | 22,40 |
| • 5,0 | R2,5 | 6 | - | 12 | - | 80 | KFB506050ZX3 | 23,40 |
| • 6,0 | R3,0 | 6 | 5,8 | 12 | 22 | 80 | KFB506060ZX3 | 25,20 |
| • 7,0 | R3,5 | 8 | - | 14 | - | 90 | KFB506070ZX3 | 39,20 |
| • 8,0 | R4,0 | 8 | 7,8 | 14 | 27 | 90 | KFB506080ZX3 | 39,40 |
| • 10,0 | R5,0 | 10 | 9,8 | 18 | 31 | 100 | KFB506100ZX3 | 64,00 |
| • 12,0 | R6,0 | 12 | 11,8 | 22 | 35 | 110 | KFB506120ZX3 | 80,40 |
| • 14,0 | R7,0 | 12 | - | 26 | - | 120 | KFB506140ZX3 | 89,40 |
| • 16,0 | R8,0 | 16 | 15,8 | 30 | 50 | 140 | KFB506160ZX3 | 114,60 |
| • 18,0 | R9,0 | 16 | - | 34 | - | 140 | KFB506180ZX3 | 124,00 |
| • 20,0 | R10,0 | 20 | 19,8 | 38 | 58 | 160 | KFB506200ZX3 | 177,80 |
| • 25,0 | R12,5 | 25 | 24,8 | 55 | 75 | 180 | KFB506250ZX3 | 297,00 |

VHM-HSC-KOPIERFRÄSER 30°

KFB504 - ZX3



Einsatzgebiete: Werkzeug und Hartmetall wurden speziell für die HSC- und Hartbearbeitung im Werkzeug- und Formenbau entwickelt. Hervorragend geeignet für die Trockenbearbeitung.

application: This tool and carbide grade were developed especially for high-speed and high-hard operations in tool making and die- and mould-making. Excellent suited for dry machining.

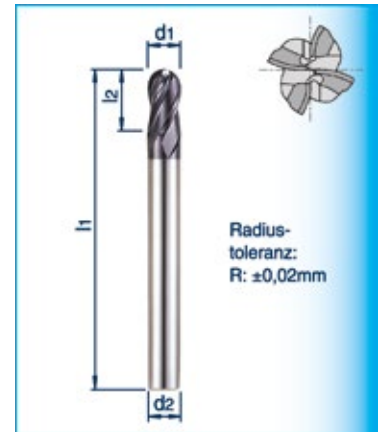

| * Durchmessertoleranz (Ø-tolerance) „e8“: | | | | |
|---|-----------------|-----------------|-----------------|-----------------|
| Ø 1 - Ø 3 | Ø 3 - Ø 6 | Ø 6 - Ø 10 | Ø 10 - Ø 18 | Ø 18 - Ø 25 |
| -0,014 / -0,028 | -0,020 / -0,038 | -0,025 / -0,047 | -0,032 / -0,059 | -0,040 / -0,073 |



- ab Lager / ex stock
- kurzfristig / on short notice
- Lieferzeit auf Anfrage / delivery time upon request

| d1 e8* mm | d2 h6 mm | l2 mm | l1 mm | Zähnezahl (no. of cutting edges) | Artikel-Nr. (code no.) | Preis Euro / je KFB504 - ZX3 |
|-----------------|----------------|----------|----------|--|---------------------------|------------------------------------|
| • 1,0 | 4,0 | 2,5 | 50 | 4 | KFB504010ZX3 | 25,60 |
| • 1,5 | 4,0 | 4,0 | 50 | 4 | KFB504015ZX3 | 25,60 |
| • 2,0 | 6,0 | 5,0 | 50 | 4 | KFB504020ZX3 | 24,40 |
| • 3,0 | 6,0 | 8,0 | 60 | 4 | KFB504030ZX3 | 24,40 |
| • 4,0 | 6,0 | 8,0 | 70 | 4 | KFB504040ZX3 | 25,20 |
| • 5,0 | 6,0 | 10,0 | 80 | 4 | KFB504050ZX3 | 26,00 |
| • 6,0 | 6,0 | 12,0 | 90 | 4 | KFB504060ZX3 | 27,60 |
| • 7,0 | 8,0 | 14,0 | 90 | 4 | KFB504070ZX3 | 40,60 |
| • 8,0 | 8,0 | 14,0 | 100 | 4 | KFB504080ZX3 | 40,60 |
| • 9,0 | 10,0 | 18,0 | 100 | 4 | KFB504090ZX3 | 62,40 |
| • 10,0 | 10,0 | 18,0 | 100 | 4 | KFB504100ZX3 | 62,40 |
| • 12,0 | 12,0 | 22,0 | 110 | 4 | KFB504120ZX3 | 78,60 |
| • 14,0 | 14,0 | 26,0 | 110 | 4 | KFB504140ZX3 | 97,20 |
| • 16,0 | 16,0 | 30,0 | 140 | 4 | KFB504160ZX3 | 128,80 |
| • 18,0 | 18,0 | 34,0 | 140 | 4 | KFB504180ZX3 | 150,60 |
| • 20,0 | 20,0 | 38,0 | 160 | 4 | KFB504200ZX3 | 214,40 |
| • 25,0 | 25,0 | 50,0 | 180 | 4 | KFB504250ZX3 | 343,20 |

VHM-MICRO-KUGELFRÄSER

KFB510 - ZX3



Einsatzgebiete: Für die 3D-Bearbeitung im Formenbau. Speziell für HSC, Hart- und Trockenbearbeitung optimiert. Eingriffstiefe bis 5xD.

application: Well suited for 3D-machining in die- and mould-making. Optimized for HSC, high-hard and dry machining. Working length up to 5xD.

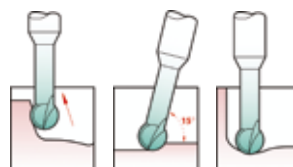
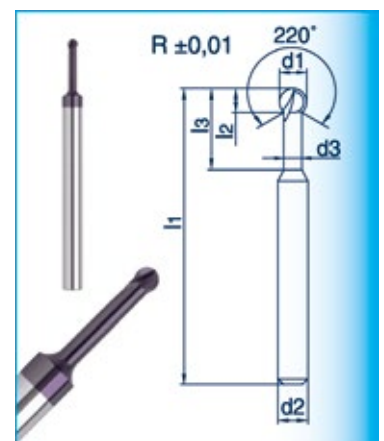

- ab Lager / ex stock
- kurzfristig / on short notice
- Lieferzeit auf Anfrage / delivery time upon request

| d1 ±0,02 mm | d2 h6 mm | d3 mm | l1 mm | l2 mm | l3 mm | Artikel-Nr. (code no.) | Preis Euro / je KFB510 - ZX3 |
|-------------------|----------------|----------|----------|----------|----------|---------------------------|------------------------------------|
| • 0,80 | 3,0 | 0,70 | 60 | 0,55 | 4,0 | KFB5100080ZX | 68,20 |
| • 1,00 | 3,0 | 0,85 | 60 | 0,70 | 5,0 | KFB5100100ZX | 64,00 |
| • 1,20 | 3,0 | 1,00 | 60 | 0,80 | 6,0 | KFB5100120ZX | 68,20 |
| • 1,50 | 3,0 | 1,30 | 60 | 1,00 | 7,5 | KFB5100150ZX | 68,80 |
| • 2,00 | 3,0 | 1,70 | 60 | 1,35 | 10,0 | KFB5100200ZX | 72,00 |
| • 3,00 | 6,0 | 2,60 | 75 | 2,00 | 15,0 | KFB5100300ZX | 80,20 |
| • 4,00 | 6,0 | 3,45 | 75 | 2,70 | 20,0 | KFB5100400ZX | 88,20 |
| • 5,00 | 6,0 | 4,30 | 75 | 3,40 | 25,0 | KFB5100500ZX | 96,20 |

VHM-HSC-KUGELFRÄSER

KFB512 / KFB514



Einsatzgebiete: Werkzeug und Hartmetall wurden speziell für die HSC- und Hartbearbeitung im Werkzeug- und Formenbau entwickelt. Hervorragend geeignet für die Trockenbearbeitung.

application: This tool and carbide grade were developed especially for high-speed and high-hard operations in tool making and die- and mould-making. Excellent suited for dry machining.

| * Durchmesser-toleranz (Ø-tolerance) „h9“: | | | | |
|--|------------|------------|-------------|-------------|
| Ø 1 - Ø 3 | Ø 3 - Ø 6 | Ø 6 - Ø 10 | Ø 10 - Ø 18 | Ø 18 - Ø 25 |
| 0 / -0,025 | 0 / -0,030 | 0 / -0,036 | 0 / -0,043 | 0 / -0,052 |

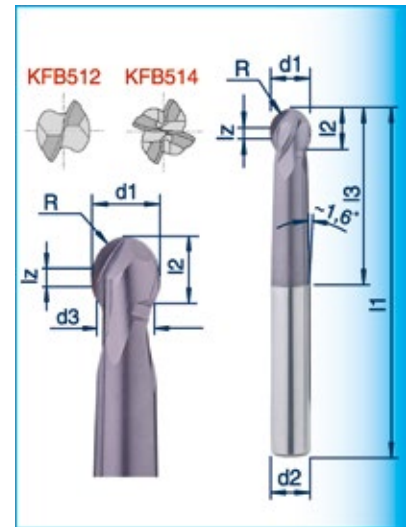

- ab Lager / ex stock
- kurzfristig / on short notice
- Lieferzeit auf Anfrage / delivery time upon request

VHM-Kugelfräser KFB512 - 2-Schneidig

| d1 h9 mm | Radius (R ±0,01) | d2 h6 mm | d3 mm | l2 mm | l3 mm | l1 mm | lz mm | Zähnezahl (no. of cutting edges) | Artikel-Nr. (code no.) | Preis Euro / je KFB512 - ZX3 |
|----------------|---------------------|----------------|----------|----------|----------|----------|----------|--|---------------------------|------------------------------------|
| • 3,0 | 1,5 | 6,0 | 2,5 | 4,0 | 30,0 | 80 | 1,5 | 2 | KFB512030ZX3 | 28,40 |
| • 4,0 | 2,0 | 6,0 | 3,3 | 5,0 | 30,0 | 80 | 1,5 | 2 | KFB512040ZX3 | 28,80 |
| • 5,0 | 2,5 | 6,0 | 4,1 | 6,0 | 43,0 | 80 | 2 | 2 | KFB512050ZX3 | 28,40 |
| • 6,0 | 3,0 | 6,0 | 4,7 | 7,0 | 30,0 | 100 | 2 | 2 | KFB512060ZX3 | 32,00 |
| • 8,0 | 4,0 | 8,0 | 6,5 | 9,0 | 36,0 | 100 | 3 | 2 | KFB512080ZX3 | 47,40 |
| • 10,0 | 5,0 | 10,0 | 8,2 | 11,0 | 43,0 | 100 | 3 | 2 | KFB512100ZX3 | 78,60 |
| • 12,0 | 6,0 | 12,0 | 9,8 | 13,0 | 52,0 | 100 | 3 | 2 | KFB512120ZX3 | 97,20 |
| • 16,0 | 8,0 | 16,0 | 13,4 | 15,0 | 61,0 | 150 | 3 | 2 | KFB512160ZX3 | 174,80 |

VHM-Kugelfräser KFB514 - 4-Schneidig

| d1 h9 mm | Radius (R ±0,01) | d2 h6 mm | d3 mm | l2 mm | l3 mm | l1 mm | lz mm | Zähnezahl (no. of cutting edges) | Artikel-Nr. (code no.) | Preis Euro / je KFB514 - ZX3 |
|----------------|---------------------|----------------|----------|----------|----------|----------|----------|--|---------------------------|------------------------------------|
| • 5,0 | 2,5 | 6,0 | 4,1 | 6,0 | 43,0 | 80 | 2 | 4 | KFB514050ZX3 | 28,40 |
| • 6,0 | 3,0 | 6,0 | 4,7 | 7,0 | 30,0 | 100 | 2 | 4 | KFB514060ZX3 | 32,00 |
| • 8,0 | 4,0 | 8,0 | 6,5 | 9,0 | 36,0 | 100 | 3 | 4 | KFB514080ZX3 | 47,40 |
| • 10,0 | 5,0 | 10,0 | 8,2 | 11,0 | 43,0 | 100 | 3 | 4 | KFB514100ZX3 | 78,60 |
| • 12,0 | 6,0 | 12,0 | 9,8 | 13,0 | 52,0 | 100 | 3 | 4 | KFB514120ZX3 | 97,20 |
| • 16,0 | 8,0 | 16,0 | 13,4 | 15,0 | 61,0 | 150 | 3 | 4 | KFB514160ZX3 | 174,80 |

VHM-HSC-HARTFRÄSER

KF600 / KF602 - ZX3



Einsatzgebiete: Werkzeug und Hartmetall wurden speziell für die HSC- und Hartbearbeitung im Werkzeug- und Formenbau entwickelt. Hervorragend geeignet für die Trockenbearbeitung.

application: This tool and carbide grade were developed especially for high-speed and high-hard operations in tool making and die- and mould-making. Excellent suited for dry machining.

KF600 = 6-8 Schneiden, lange Ausführung, Zylinderschaft DIN6535-HB (Weldon-Spannfläche)
 KF602 = 6-8 Schneiden, Extra lange Ausführung, Zylinderschaft DIN6535-HB (Weldon-Spannfläche)
 KF605 = 6-8 Schneiden, mit Eckenradius, Zylinderschaft DIN6535-HA



| * Durchmessertoleranz (Ø-tolerance) „e8“: | | | |
|---|-----------------|-----------------|-----------------|
| Ø 3 - Ø 6 | Ø 6 - Ø 10 | Ø 10 - Ø 18 | Ø 18 - Ø 25 |
| -0,020 / -0,038 | -0,025 / -0,047 | -0,032 / -0,059 | -0,040 / -0,073 |

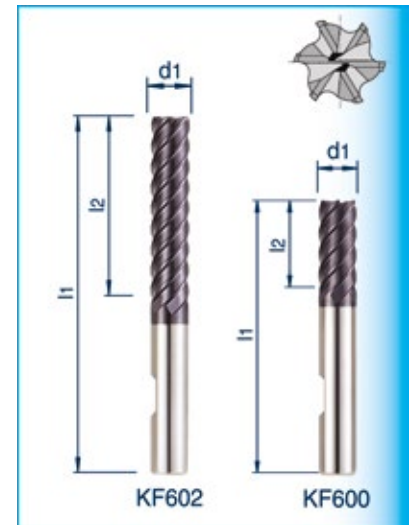

- ab Lager / ex stock
- kurzfristig / on short notice
- Lieferzeit auf Anfrage / delivery time upon request

VHM-HSC-HARTFRÄSER

| | d1 h10 mm | d2 h6 mm | l1 mm | l2 mm | Zähnezahl (no. of cutting edges) | Artikel-Nr. (code no.) | Preis Euro / je KF600/602 - ZX3 |
|---|-----------------|----------------|----------|----------|--|---------------------------|---------------------------------------|
| • | 6,0 | 6,0 | 13 | 57 | 6 | KF600060ZX3 | 22,00 |
| • | 6,0 | 6,0 | 26 | 70 | 6 | KF602060ZX3 | 28,60 |
| • | 7,0 | 8,0 | 16 | 63 | 6 | KF600070ZX3 | 28,00 |
| • | 8,0 | 8,0 | 19 | 63 | 6 | KF600080ZX3 | 28,00 |
| • | 8,0 | 8,0 | 36 | 90 | 6 | KF602080ZX3 | 37,60 |
| • | 9,0 | 10,0 | 19 | 72 | 6 | KF600090ZX3 | 41,80 |
| • | 10,0 | 10,0 | 22 | 72 | 6 | KF600100ZX3 | 41,80 |
| • | 10,0 | 10,0 | 46 | 100 | 6 | KF602100ZX3 | 58,60 |
| • | 12,0 | 12,0 | 26 | 83 | 6 | KF600120ZX3 | 56,60 |
| • | 12,0 | 12,0 | 56 | 110 | 6 | KF602120ZX3 | 82,20 |
| • | 14,0 | 14,0 | 26 | 83 | 6 | KF602140ZX3 | 71,00 |
| • | 16,0 | 16,0 | 32 | 92 | 6 | KF600160ZX3 | 95,00 |
| • | 16,0 | 16,0 | 66 | 130 | 6 | KF600160ZX3 | 142,60 |
| • | 18,0 | 18,0 | 32 | 92 | 8 | KF600180ZX3 | 111,40 |
| • | 20,0 | 20,0 | 38 | 104 | 8 | KF600200ZX3 | 139,80 |
| • | 20,0 | 20,0 | 76 | 140 | 6 | KF602200ZX3 | 222,80 |
| • | 25,0 | 25,0 | 44 | 104 | 8 | KF600250ZX3 | 246,40 |
| • | 25,0 | 25,0 | 92 | 180 | 6 | KF602250ZX3 | 419,00 |

VHM-SCHAFTFRÄSER MIT ECKENRADIUS

KF506 - ZX3



Einsatzgebiete: Werkzeug und Hartmetall wurden speziell für die HSC- und Hartbearbeitung im Werkzeug- und Formenbau entwickelt. Hervorragend geeignet für die Trockenbearbeitung.

application: This tool and carbide grade were developed especially for high-speed and high-hard operations in tool making and die- and mould-making. Excellent suited for dry machining.

| * Durchmesser-toleranz (Ø-tolerance) „e8“: | | | | |
|--|-----------------|-----------------|-----------------|-----------------|
| Ø 1 - Ø 3 | Ø 3 - Ø 6 | Ø 6 - Ø 10 | Ø 10 - Ø 18 | Ø 18 - Ø 25 |
| -0,014 / -0,028 | -0,020 / -0,038 | -0,025 / -0,047 | -0,032 / -0,059 | -0,040 / -0,073 |

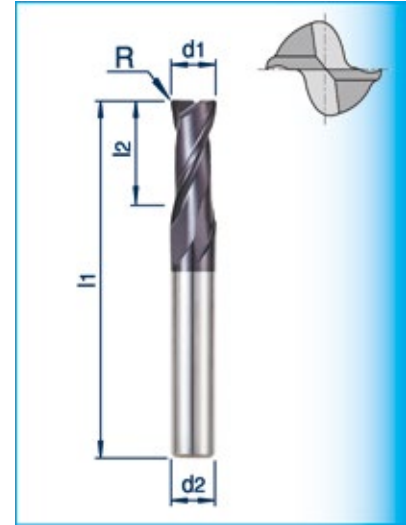

- ab Lager / ex stock
- kurzfristig / on short notice
- Lieferzeit auf Anfrage / delivery time upon request

| | d1 e8 mm | d2 h6 mm | Eckenradius R (corner radius) mm | l2 mm | l1 mm | Zähnezahl (no. of cutting edges) | Artikel-Nr. (code no.) | Preis Euro / je KF506 - ZX3 |
|---|----------------|----------------|--|----------|----------|--|---------------------------|-----------------------------------|
| • | 3,0 | 6,0 | 0,3 | 12 | 50 | 2 | KF506030ZX31 | 25,00 |
| • | 4,0 | 6,0 | 0,3 | 15 | 50 | 2 | KF506040ZX31 | 25,00 |
| • | 4,0 | 6,0 | 0,5 | 15 | 50 | 2 | KF506040ZX32 | 25,00 |
| • | 5,0 | 6,0 | 0,3 | 20 | 60 | 2 | KF506050ZX31 | 25,00 |
| • | 5,0 | 6,0 | 0,5 | 20 | 60 | 2 | KF506050ZX32 | 25,00 |
| • | 6,0 | 6,0 | 0,5 | 20 | 60 | 2 | KF506060ZX31 | 25,00 |
| • | 6,0 | 6,0 | 1,0 | 20 | 60 | 2 | KF506060ZX32 | 25,00 |
| • | 8,0 | 8,0 | 0,5 | 25 | 70 | 2 | KF506080ZX31 | 31,80 |
| • | 8,0 | 8,0 | 1,0 | 25 | 70 | 2 | KF506080ZX32 | 31,80 |
| • | 8,0 | 8,0 | 1,5 | 25 | 70 | 2 | KF506080ZX33 | 34,80 |
| • | 8,0 | 8,0 | 2,0 | 25 | 70 | 2 | KF506080ZX34 | 34,80 |
| • | 10,0 | 10,0 | 0,5 | 30 | 90 | 2 | KF506100ZX31 | 47,00 |
| • | 10,0 | 10,0 | 1,0 | 30 | 90 | 2 | KF506100ZX32 | 47,00 |
| • | 10,0 | 10,0 | 1,5 | 30 | 90 | 2 | KF506100ZX33 | 51,20 |
| • | 10,0 | 10,0 | 2,0 | 30 | 90 | 2 | KF506100ZX34 | 51,20 |
| • | 12,0 | 12,0 | 0,5 | 30 | 90 | 2 | KF506120ZX31 | 64,20 |
| • | 12,0 | 12,0 | 1,0 | 30 | 90 | 2 | KF506120ZX32 | 64,20 |
| • | 12,0 | 12,0 | 1,5 | 30 | 90 | 2 | KF506120ZX33 | 70,00 |
| • | 12,0 | 12,0 | 2,0 | 30 | 90 | 2 | KF506120ZX34 | 70,00 |

VHM-SCHAFTFRÄSER MIT ECKENRADIUS

KF508 / KF509 - ZX3



Einsatzgebiete: Werkzeug und Hartmetall wurden speziell für die HSC- und Hartbearbeitung im Werkzeug- und Formenbau entwickelt. Hervorragend geeignet für die Trockenbearbeitung.

application: This tool and carbide grade were developed especially for high-speed and high-hard operations in tool making and die- and mould-making. Excellent suited for dry machining.



| * Durchmesser-toleranz (Ø-tolerance) „e8“: | | | | |
|--|-----------------|-----------------|-----------------|-----------------|
| Ø 1 - Ø 3 | Ø 3 - Ø 6 | Ø 6 - Ø 10 | Ø 10 - Ø 18 | Ø 18 - Ø 25 |
| -0,014 / -0,028 | -0,020 / -0,038 | -0,025 / -0,047 | -0,032 / -0,059 | -0,040 / -0,073 |



- ab Lager / ex stock
- kurzfristig / on short notice
- Lieferzeit auf Anfrage / delivery time upon request

VHM-Schaftfräser mit Eckenradius - zylindrisch abgesetzt

| | d1 | d2 | d3 | Eckenradius R | l3 | l2 | l1 | Zähnezahl | Artikel-Nr. | Preis |
|---|------|------|------|-----------------|------|------|----|------------------------|-------------|-------------|
| | e8 | h6 | h6 | (corner radius) | mm | mm | mm | (no. of cutting edges) | (code no.) | Euro / je |
| | mm | mm | mm | mm | mm | mm | mm | | | KF508 - ZX3 |
| • | 2,0 | 6,0 | 1,9 | 0,20 | 5,0 | 2,5 | 50 | 4 | KF508020ZX3 | 20,80 |
| • | 2,5 | 6,0 | 2,4 | 0,25 | 6,0 | 3,0 | 50 | 4 | KF508025ZX3 | 20,80 |
| • | 3,0 | 6,0 | 2,8 | 0,30 | 7,0 | 4,0 | 50 | 4 | KF508030ZX3 | 20,80 |
| • | 3,5 | 6,0 | 3,2 | 0,35 | 8,0 | 4,5 | 50 | 4 | KF508035ZX3 | 20,80 |
| • | 4,0 | 6,0 | 3,7 | 0,40 | 9,0 | 5,0 | 50 | 4 | KF508040ZX3 | 20,80 |
| • | 5,0 | 6,0 | 4,6 | 0,50 | 12,0 | 6,0 | 50 | 4 | KF508050ZX3 | 20,80 |
| • | 6,0 | 6,0 | 5,6 | 0,60 | 14,0 | 7,0 | 55 | 4 | KF508060ZX3 | 20,80 |
| • | 8,0 | 8,0 | 7,4 | 0,80 | 18,0 | 10,0 | 60 | 4 | KF508080ZX3 | 26,60 |
| • | 10,0 | 10,0 | 9,4 | 1,00 | 25,0 | 12,0 | 70 | 4 | KF508100ZX3 | 39,20 |
| • | 12,0 | 12,0 | 11,4 | 1,20 | 30,0 | 15,0 | 80 | 4 | KF508120ZX3 | 53,60 |
| • | 16,0 | 16,0 | 15,4 | 1,60 | 35,0 | 18,0 | 90 | 4 | KF508160ZX3 | 97,00 |

VHM-Schaftfräser mit Eckenradius

| | d1 | d2 | Eckenradius R | l2 | l1 | Zähnezahl | Artikel-Nr. | Preis |
|---|------|------|-----------------|----|----|------------------------|--------------|-------------|
| | e8 | h6 | (corner radius) | mm | mm | (no. of cutting edges) | (code no.) | Euro / je |
| | mm | mm | mm | mm | mm | | | KF509 - ZX3 |
| • | 3,0 | 6,0 | 0,3 | 12 | 50 | 4 | KF509030ZX31 | 27,40 |
| • | 4,0 | 6,0 | 0,3 | 15 | 50 | 4 | KF509040ZX31 | 27,40 |
| • | 4,0 | 6,0 | 0,5 | 15 | 50 | 4 | KF509040ZX32 | 27,40 |
| • | 5,0 | 6,0 | 0,3 | 20 | 60 | 4 | KF509050ZX31 | 27,40 |
| • | 5,0 | 6,0 | 0,5 | 20 | 60 | 4 | KF509050ZX32 | 27,40 |
| • | 6,0 | 6,0 | 0,5 | 20 | 60 | 4 | KF509060ZX31 | 27,40 |
| • | 6,0 | 6,0 | 1,0 | 20 | 60 | 4 | KF509060ZX32 | 27,40 |
| • | 8,0 | 8,0 | 0,5 | 25 | 70 | 4 | KF509080ZX31 | 35,00 |
| • | 8,0 | 8,0 | 1,0 | 25 | 70 | 4 | KF509080ZX32 | 35,00 |
| • | 8,0 | 8,0 | 1,5 | 25 | 70 | 4 | KF509080ZX33 | 38,00 |
| • | 8,0 | 8,0 | 2,0 | 25 | 70 | 4 | KF509080ZX34 | 38,00 |
| • | 10,0 | 10,0 | 0,5 | 30 | 90 | 4 | KF509100ZX31 | 51,60 |
| • | 10,0 | 10,0 | 1,0 | 30 | 90 | 4 | KF509100ZX32 | 51,60 |
| • | 10,0 | 10,0 | 1,5 | 30 | 90 | 4 | KF509100ZX33 | 56,40 |
| • | 10,0 | 10,0 | 2,0 | 30 | 90 | 4 | KF509100ZX34 | 56,40 |
| • | 12,0 | 12,0 | 0,5 | 30 | 90 | 4 | KF509120ZX31 | 70,80 |
| • | 12,0 | 12,0 | 1,0 | 30 | 90 | 4 | KF509120ZX32 | 70,80 |
| • | 12,0 | 12,0 | 1,5 | 30 | 90 | 4 | KF509120ZX33 | 77,20 |
| • | 12,0 | 12,0 | 2,0 | 30 | 90 | 4 | KF509120ZX34 | 77,20 |

VHM-SCHAFTFRÄSER Kurze und Lange Ausführung

KF502 - ZX3



Einsatzgebiete: Werkzeug und Hartmetall wurden speziell für die HSC- und Hartbearbeitung im Werkzeug- und Formenbau entwickelt. Hervorragend geeignet für die Trockenbearbeitung.

application: This tool and carbide grade were developed especially for high-speed and high-hard operations in tool making and die- and mould-making. Excellent suited for dry machining.

| * Durchmesser-toleranz (Ø-tolerance) „e8“: | | | | |
|--|-----------------|-----------------|-----------------|-----------------|
| Ø 1 - Ø 3 | Ø 3 - Ø 6 | Ø 6 - Ø 10 | Ø 10 - Ø 18 | Ø 18 - Ø 25 |
| -0,014 / -0,028 | -0,020 / -0,038 | -0,025 / -0,047 | -0,032 / -0,059 | -0,040 / -0,073 |



Diese Schaftfräser sind in ähnlichen Baumaßen auch als 3-Schneider kurzfristig erhältlich. These end mills are also available with 3 cutting edges on short notice upon request.

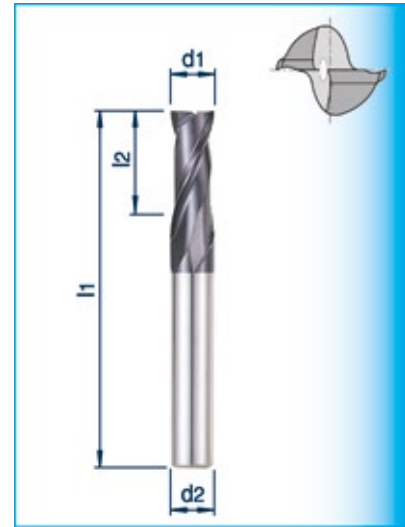

- ab Lager / ex stock
- kurzfristig / on short notice
- Lieferzeit auf Anfrage / delivery time upon request

| d1 e8 mm | d2 h6 mm | l2 mm | l1 mm | Artikel-Nr. (code no.) K=Kurz L=Lang | Preis Euro / je ZX3 | d1 h10 mm | d2 h6 mm | l2 mm | l1 mm | Artikel-Nr. (code no.) K=Kurz L=Lang | Preis Euro / je ZX3 |
|----------------|----------------|----------|----------|---|---------------------------|-----------------|----------------|----------|----------|---|---------------------------|
| • 1,0 | 4,0 | 2,5 | 40 | KF502010ZX3K | 14,40 | • 10,0 | 10,0 | 22,0 | 70 | KF502100ZX3K | 35,60 |
| • 1,5 | 4,0 | 4,0 | 40 | KF502015ZX3K | 14,40 | • 10,0 | 10,0 | 30,0 | 90 | KF502100ZX3L | 42,60 |
| • 2,0 | 4,0 | 6,0 | 40 | KF502020ZX3K | 13,00 | • 10,5 | 12,0 | 22,0 | 75 | KF502105ZX3K | 48,80 |
| • 2,0 | 4,0 | 8,0 | 40 | KF502020ZX3L | 15,80 | • 11,0 | 12,0 | 22,0 | 75 | KF502110ZX3K | 48,80 |
| • 2,5 | 4,0 | 8,0 | 40 | KF502025ZX3K | 13,00 | • 11,5 | 12,0 | 22,0 | 75 | KF502115ZX3K | 48,80 |
| • 3,0 | 6,0 | 8,0 | 45 | KF502030ZX3K | 19,00 | • 12,0 | 12,0 | 26,0 | 75 | KF502120ZX3K | 48,80 |
| • 3,0 | 6,0 | 12,0 | 50 | KF502030ZX3L | 22,60 | • 12,0 | 12,0 | 30,0 | 90 | KF502120ZX3L | 58,60 |
| • 3,5 | 6,0 | 10,0 | 45 | KF502035ZX3K | 19,00 | • 13,0 | 12,0 | 26,0 | 85 | KF502130ZX3K | 61,80 |
| • 4,0 | 6,0 | 11,0 | 45 | KF502040ZX3K | 19,00 | • 14,0 | 14,0 | 26,0 | 85 | KF502140ZX3K | 61,80 |
| • 4,0 | 6,0 | 15,0 | 50 | KF502040ZX3L | 22,60 | • 14,0 | 16,0 | 40,0 | 110 | KF502140ZX3L | 83,40 |
| • 4,5 | 6,0 | 11,0 | 45 | KF502045ZX3K | 19,00 | • 15,0 | 16,0 | 26,0 | 90 | KF502150ZX3K | 80,80 |
| • 5,0 | 6,0 | 13,0 | 50 | KF502050ZX3K | 19,00 | • 16,0 | 16,0 | 32,0 | 100 | KF502160ZX3K | 80,80 |
| • 5,0 | 6,0 | 20,0 | 60 | KF502050ZX3L | 22,60 | • 16,0 | 16,0 | 50,0 | 110 | KF502160ZX3L | 109,20 |
| • 5,5 | 6,0 | 13,0 | 50 | KF502055ZX3K | 19,00 | • 17,0 | 16,0 | 32,0 | 100 | KF502170ZX3K | 107,20 |
| • 6,0 | 6,0 | 13,0 | 50 | KF502060ZX3K | 19,00 | • 18,0 | 18,0 | 32,0 | 100 | KF502180ZX3K | 107,20 |
| • 6,0 | 6,0 | 20,0 | 60 | KF502060ZX3L | 22,60 | • 18,0 | 20,0 | 50,0 | 110 | KF502180ZX3L | 148,00 |
| • 6,5 | 8,0 | 16,0 | 60 | KF502065ZX3K | 24,20 | • 19,0 | 20,0 | 32,0 | 100 | KF502190ZX3K | 134,00 |
| • 7,0 | 8,0 | 16,0 | 60 | KF502070ZX3K | 24,20 | • 20,0 | 20,0 | 38,0 | 105 | KF502200ZX3K | 134,00 |
| • 7,5 | 8,0 | 16,0 | 60 | KF502075ZX3K | 24,20 | • 20,0 | 20,0 | 55,0 | 110 | KF502200ZX3L | 180,60 |
| • 8,0 | 8,0 | 19,0 | 60 | KF502080ZX3K | 24,20 | • 22,0 | 20,0 | 38,0 | 105 | KF502220ZX3K | 174,00 |
| • 8,0 | 8,0 | 25,0 | 70 | KF502080ZX3L | 28,80 | • 24,0 | 25,0 | 45,0 | 120 | KF502240ZX3K | 214,00 |
| • 8,5 | 10,0 | 19,0 | 70 | KF502085ZX3K | 35,60 | • 25,0 | 25,0 | 45,0 | 120 | KF502250ZX3K | 214,00 |
| • 9,0 | 10,0 | 19,0 | 70 | KF502090ZX3K | 35,60 | • 25,0 | 25,0 | 75,0 | 140 | KF502250ZX3L | 288,80 |
| • 9,5 | 10,0 | 19,0 | 70 | KF502095ZX3K | 35,60 | | | | | | |

VHM-SCHAFTFRÄSER Kurze und Lange Ausführung

KF504 - ZX3



Einsatzgebiete: Werkzeug und Hartmetall wurden speziell für die HSC- und Hartbearbeitung im Werkzeug- und Formenbau entwickelt. Hervorragend geeignet für die Trockenbearbeitung.

application: This tool and carbide grade were developed especially for high-speed and high-hard operations in tool making and die- and mould-making. Excellent suited for dry machining.

* Durchmesser tolerance (Ø-tolerance) „e8“:

| | | | | |
|-----------------|-----------------|-----------------|-----------------|-----------------|
| Ø 1 - Ø 3 | Ø 3 - Ø 6 | Ø 6 - Ø 10 | Ø 10 - Ø 18 | Ø 18 - Ø 25 |
| -0,014 / -0,028 | -0,020 / -0,038 | -0,025 / -0,047 | -0,032 / -0,059 | -0,040 / -0,073 |

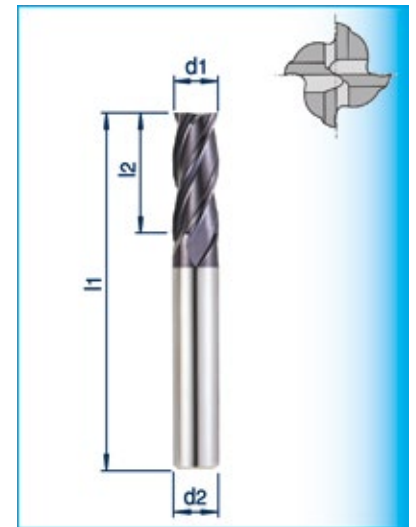

- ab Lager / ex stock
- kurzfristig / on short notice
- Lieferzeit auf Anfrage / delivery time upon request

| d1 e8 mm | d2 h6 mm | l2 mm | l1 mm | Artikel-Nr. (code no.) K=Kurz L=Lang | Preis Euro / je ZX3 | d1 h10 mm | d2 h6 mm | l2 mm | l1 mm | Artikel-Nr. (code no.) K=Kurz L=Lang | Preis Euro / je ZX3 |
|----------------|----------------|----------|----------|---|---------------------------|-----------------|----------------|----------|----------|---|---------------------------|
| • 2,0 | 4,0 | 6,0 | 40 | KF504020ZX3K | 13,00 | • 10,0 | 10,0 | 30,0 | 90 | KF504100ZX3L | 42,60 |
| • 2,0 | 4,0 | 8,0 | 40 | KF504020ZX3L | 15,80 | • 10,5 | 12,0 | 22,0 | 75 | KF504105ZX3K | 48,80 |
| • 2,5 | 4,0 | 8,0 | 40 | KF504025ZX3K | 13,00 | • 11,0 | 12,0 | 22,0 | 75 | KF504110ZX3K | 48,80 |
| • 3,0 | 6,0 | 8,0 | 45 | KF504030ZX3K | 19,00 | • 11,5 | 12,0 | 22,0 | 75 | KF504115ZX3K | 48,80 |
| • 3,0 | 6,0 | 12,0 | 50 | KF504030ZX3L | 22,60 | • 12,0 | 12,0 | 26,0 | 75 | KF504120ZX3K | 48,80 |
| • 3,5 | 6,0 | 10,0 | 45 | KF504035ZX3K | 19,00 | • 12,0 | 12,0 | 30,0 | 90 | KF504120ZX3L | 58,60 |
| • 4,0 | 6,0 | 11,0 | 45 | KF504040ZX3K | 19,00 | • 13,0 | 12,0 | 26,0 | 85 | KF504130ZX3K | 61,80 |
| • 4,0 | 6,0 | 15,0 | 50 | KF504040ZX3L | 22,60 | • 14,0 | 14,0 | 26,0 | 85 | KF504140ZX3K | 61,80 |
| • 4,5 | 6,0 | 11,0 | 45 | KF504045ZX3K | 19,00 | • 14,0 | 16,0 | 40,0 | 110 | KF504140ZX3L | 83,40 |
| • 5,0 | 6,0 | 13,0 | 50 | KF504050ZX3K | 19,00 | • 15,0 | 16,0 | 26,0 | 90 | KF504150ZX3K | 80,80 |
| • 5,0 | 6,0 | 20,0 | 60 | KF504050ZX3L | 22,60 | • 16,0 | 16,0 | 32,0 | 100 | KF504160ZX3K | 80,80 |
| • 5,5 | 6,0 | 13,0 | 50 | KF504055ZX3K | 19,00 | • 16,0 | 16,0 | 50,0 | 110 | KF504160ZX3L | 109,20 |
| • 6,0 | 6,0 | 13,0 | 50 | KF504060ZX3K | 19,00 | • 17,0 | 16,0 | 32,0 | 100 | KF504170ZX3K | 107,20 |
| • 6,0 | 6,0 | 20,0 | 60 | KF504060ZX3L | 22,60 | • 18,0 | 18,0 | 32,0 | 100 | KF504180ZX3K | 107,20 |
| • 6,5 | 8,0 | 16,0 | 60 | KF504065ZX3K | 24,20 | • 18,0 | 20,0 | 50,0 | 110 | KF504180ZX3L | 148,00 |
| • 7,0 | 8,0 | 16,0 | 60 | KF504070ZX3K | 24,20 | • 19,0 | 20,0 | 32,0 | 100 | KF504190ZX3K | 134,00 |
| • 7,5 | 8,0 | 16,0 | 60 | KF504075ZX3K | 24,20 | • 20,0 | 20,0 | 38,0 | 105 | KF504200ZX3K | 134,00 |
| • 8,0 | 8,0 | 19,0 | 60 | KF504080ZX3K | 24,20 | • 20,0 | 20,0 | 55,0 | 110 | KF504200ZX3L | 180,60 |
| • 8,0 | 8,0 | 25,0 | 70 | KF504080ZX3L | 28,80 | • 22,0 | 20,0 | 38,0 | 105 | KF504220ZX3K | 174,00 |
| • 8,5 | 10,0 | 19,0 | 70 | KF504085ZX3K | 35,60 | • 24,0 | 25,0 | 45,0 | 120 | KF504240ZX3K | 214,00 |
| • 9,0 | 10,0 | 19,0 | 70 | KF504090ZX3K | 35,60 | • 25,0 | 25,0 | 45,0 | 120 | KF504250ZX3K | 214,00 |
| • 9,5 | 10,0 | 19,0 | 70 | KF504095ZX3K | 35,60 | • 25,0 | 25,0 | 75,0 | 140 | KF504250ZX3L | 288,80 |
| • 10,0 | 10,0 | 22,0 | 70 | KF504100ZX3K | 35,60 | | | | | | |

Anfragebogen für VHM-Sonderfräser (questionnaire for special solid carbide end mills)

Bearbeitung von /
mat. to be machined:

- Stahl (steel)
- GUß (cast iron)
- AL (aluminium)
- Graphit (graphite)

Werkstoff Bezeichnung
(material description):

.....

Schneidenanzahl /
No. of flutes:

- 2 Schneiden (2 flutes)
 - 3 Schneiden (3 flutes)
 - 4 Schneiden (4 flutes)
 - 6 Schneiden (6 flutes)
 - sonstige (other)
-

über Mitte schneidend
(center cutting)

Spiralwinkel
helix angle

- 30°
- 45°
- 55°
- 60°

andere / other

Beschichtung /
coating:

- ZX3 (TiAlN)
- ZX5 (TiCN)
- TiN
- Diamant (diamond)
- unbeschichtet /
(uncoated)

andere / other

interne Kühlmittelzufuhr
internal coolant (IC):

- mit IK (with IC)
- ohne IK (without IC)

Anfrage (inquiry)

Bestellung (order)

Stückzahl (quantity):

.....

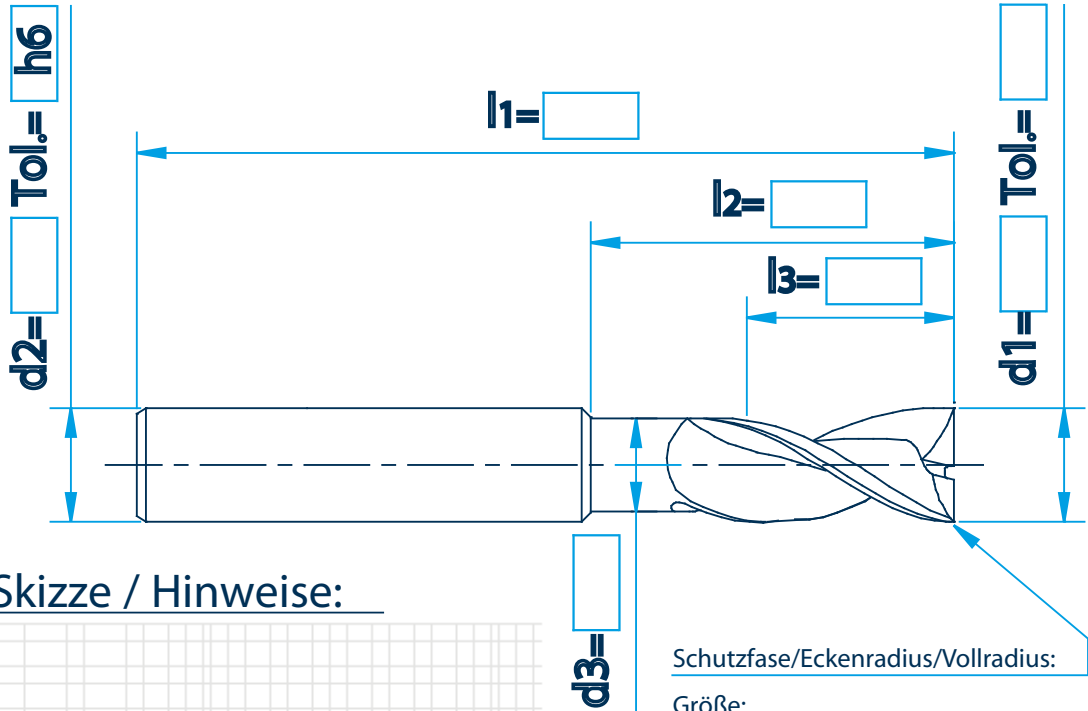

Skizze / Hinweise:

Grid area for sketching and notes.

Firma (company):

Straße (street):

Ort (town):

PLZ (zip code):

Land (country):







Ansprechpartner (contact):

e-mail:

Telefon (phone):

Telefax (fax):

Schaftformen DIN6535 (shank type):

- Form HA 
- Form HAK 
- Form HE 
- Form HEK 
- Form HB 
- Form HBK 

ENTGRATSPEZIALIST KEMPF

Entgraten Sie Ihre Bohrungen mit einzigartigen Entgratwerkzeuflösungen von Kempf. Wir bieten Ihnen im Bereich der Entgratwerkzeuge deutschlandweit die größte Auswahl und Vielfalt an standardisierten Problemlösern.

Ob wirtschaftliches Entgraten bei geringen Stückzahlen oder prozesssichere Bearbeitung in der Serienproduktion - Wir haben für jedes Entgratproblem die optimale Lösung!



Feinentgraten, Kantenverrunden und Oberflächenfinish mit High-Tech-Werkstoff

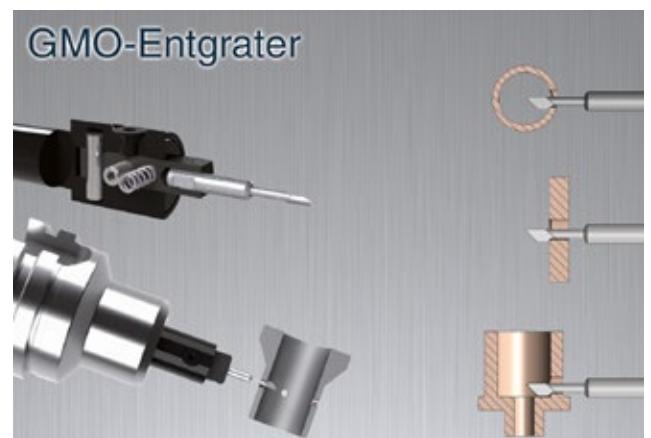

Entgraten an schwer zugänglichen Stellen und gewölbten Flächen ab \varnothing 0,8mm



Wirtschaftliches Entgraten von Vorder- und Rückseite ab \varnothing 0,8mm



Prozesssicheres High-Speed-Entgraten von Querbohrungen

Produkt- und Kompetenzvielfalt

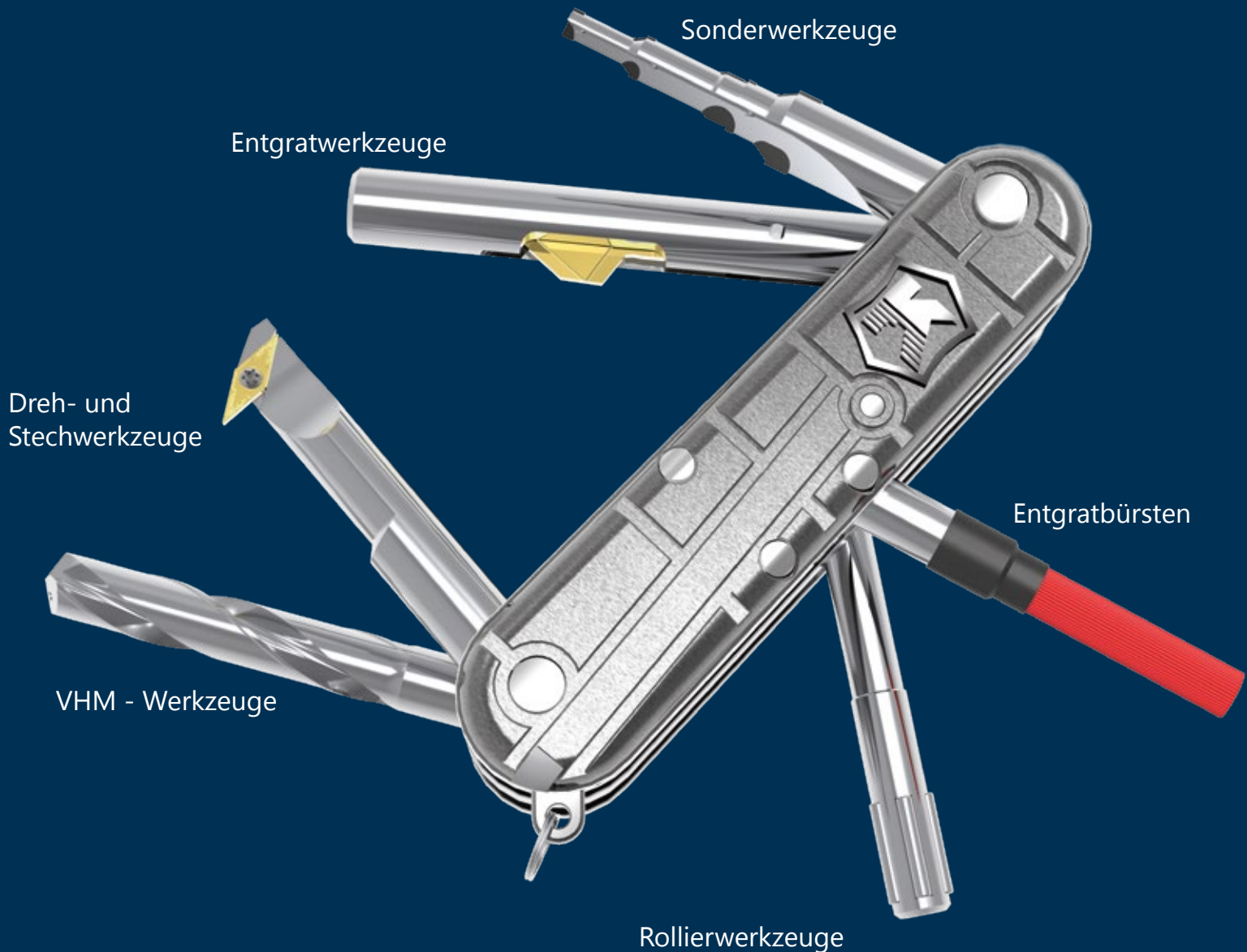

Vielfalt vereint

Unser Team freut sich auf Sie!

Kempf GmbH
Sonderwerkzeuge in Präzision
Leintelstraße 8
73262 Reichenbach an der Fils

Tel: +49 (0) 71 53 95 49 0
Fax: +49 (0) 71 53 95 49 49
Email: team@kempf-tools.de
Web: www.kempf-tools.de